

**Version**  
**2004-01-22**

# MIRSI

## Operator's Guide

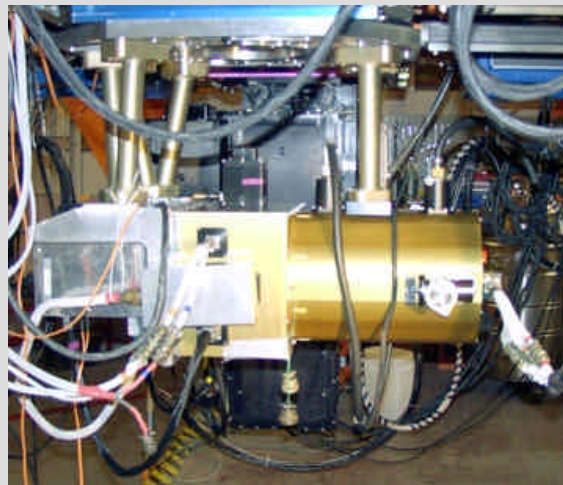

**Joseph D. Adams & Marc Kassis**  
*Boston University*  
*Institute for Astrophysical Research*

**Lynne K. Deutsch & Joseph L. Hora**  
*Harvard-Smithsonian Center for Astrophysics*

# Table of Contents

<b>1. INTRODUCTION.....</b>	<b>3</b>
<b>1.1 MIRSI overview and purpose of this manual .....</b>	<b>4</b>
<b>1.2 MIRSI personnel contact info.....</b>	<b>5</b>
<b>1.3 Engineering vendor contacts.....</b>	<b>6</b>
<b>2. PREPARING MIRSI FOR AN OBSERVING RUN.....</b>	<b>8</b>
<b>2.1 IRTF contact info.....</b>	<b>8</b>
<b>2.2 Cryogenics at IRTF .....</b>	<b>8</b>
<b>2.3 Timescale guidelines .....</b>	<b>9</b>
<b>2.4 Packing inventory and weight distribution .....</b>	<b>9</b>
Case 1 – 185 lbs. ....	10
Case 2 – 160 lbs. ....	10
Case 3 – 120 lbs. ....	10
Case 4 – 80 lbs. ....	11
Case 5 – 180 lbs. ....	12
Case 6 – 90 lbs. ....	13
Case 7 – 40 lbs. ....	13
<b>2.5 Suggested shipping crate labels and orientation markers .....</b>	<b>13</b>
<b>3. SETTING UP MIRSI .....</b>	<b>18</b>
<b>3.1 Unpacking and inspection .....</b>	<b>18</b>
<b>3.2 Host Computer .....</b>	<b>18</b>
<b>3.3 System Check .....</b>	<b>19</b>
3.3.1 Electronics.....	19
3.3.2 Array .....	19
<b>3.4 Dewar evacuation using vacuum pump .....</b>	<b>19</b>
<b>3.5 Cooldown .....</b>	<b>20</b>
3.5.1 Pre-cool .....	20
3.5.2 LHe cooldown.....	20
<b>3.6 Mount.....</b>	<b>20</b>
<b>3.7 Camera Electronics.....</b>	<b>21</b>
3.7.1 Electronics setup .....	21
3.7.2 Source Follower Gain test.....	22
<b>3.8 Motor Control System .....</b>	<b>23</b>
<b>3.9 Temperature Control.....</b>	<b>23</b>
3.9.1 Setup .....	23

3.9.2 Operation of temperature controller.....	24
3.9.3 Operation of temperature monitor .....	24
3.9.4 Temperature log.....	24
<b>3.10 Telescope.....</b>	<b>25</b>
3.10.1 Secondary mirror .....	25
3.10.2 Balance.....	25
<b>4. OPERATING MIRSI.....</b>	<b>26</b>
<b>5. OBSERVING WITH MIRSI.....</b>	<b>28</b>
<b>5.1 Telescope interface at IRTF.....</b>	<b>28</b>
5.1.1 Sending commands to the Telescope Control System.....	28
5.1.2 Chopping.....	28
5.1.3 Nodding.....	29
5.1.4 Collimation .....	29
5.1.5 Target lists.....	29
5.1.6 Standard stars.....	30
5.1.7 Telescope offsets and dither/mosaic procedures.....	30
<b>5.2 Log sheets.....</b>	<b>30</b>
<b>MIRSI OBSERVING PLAN.....</b>	<b>31</b>
<b>MIRSI SETUP.....</b>	<b>32</b>
<b>MIRSI CRYOGEN LOG .....</b>	<b>34</b>
<b>6. END OF RUN TASKS.....</b>	<b>35</b>
<b>APPENDIX.....</b>	<b>36</b>
<b>CHECK LIST FOR MIRSI SETUP .....</b>	<b>37</b>
<b>MIRSI NIGHTLY OBSERVING CHECK LISTS.....</b>	<b>38</b>
General Startup .....	38
Shutdown .....	38
<b>MIRSI TROUBLESHOOTING GUIDE .....</b>	<b>39</b>
<b>TIMING SCHEME CONCEPT, EXPOSURE PARAMETERS, AND IMAGE ACQUISITION TIME</b> <b>.....</b>	<b>42</b>
<b>SYSTEM TAPE BACKUP.....</b>	<b>45</b>
<b>WIRING DIAGRAMS .....</b>	<b>46</b>
Electronics Box to boards wiring.....	46
CONTROLLER BOX.....	47
JFET current source box .....	48
Peripheral components.....	49
Chop driver board .....	55
BNC chop box.....	56

# 1. INTRODUCTION

## 1.1 MIRSI overview and purpose of this manual

MIRSI is a mid-infrared spectrometer and imager that has been designed for operation at the NASA Infrared Telescope Facility (IRTF), on Mauna Kea, Hawaii. Its sensitivity at mid-infrared wavelengths and multiple capabilities make it a state-of-the-art tool for the study of star formation processes in the Milky Way, planetary nebulae, young stellar objects, circumstellar dust, and solar system objects.

MIRSI's capabilities span broad and narrow band imaging (2 – 26  $\mu\text{m}$ ), imaging at a selectable wavelength with a circular variable filter (CVF) (7 – 14  $\mu\text{m}$ ), and grism spectroscopy (10 and 20  $\mu\text{m}$ ). The camera operates within a vacuum chamber, on a plate that is cooled to liquid helium temperatures using a 2-stage cryostat. The first stage is cooled using liquid nitrogen. For technical specifications of the instrument and its capabilities, see Deutsch et al. in *Astronomical Telescopes and Instrumentation* (2002, SPIE, in press), or view the AAS poster by Deutsch et al. (2001); both papers are available on the MIRSI web site at <http://mirador.bu.edu/mirsi/>.

The primary purpose of this manual is to document the steps required to operate MIRSI in the lab and at the telescope. As a visiting instrument at the IRTF, MIRSI requires transport to and from the Mauna Kea summit, so the current contact information and packing lists that should help facilitate the shipping ordeal have been included. A brief troubleshooting guide documents a few bugs in MIRSI that are persistent and not necessarily understood, but usually predictable and easy to fix.

For a discussion of the principles of mid-infrared observing, and for lists of IR standard stars for flux calibration and other references, see the *MIRAC3 User's Manual* (W. Hoffmann & J. Hora 1999), online at <http://cfa-www.harvard.edu/~jhora/mirac/mrcman.pdf>.

## 1.2 MIRSI personnel contact info

Harvard-Smithsonian Center for Astrophysics  
60 Garden Street  
Cambridge, MA 02138

P.I. Lynne Deutsch

[ldeutsch@cfa.harvard.edu](mailto:ldeutsch@cfa.harvard.edu)

PH: 617-384-8209

FAX: 617-495-7490

Co-I Joe Hora

[jhora@cfa.harvard.edu](mailto:jhora@cfa.harvard.edu)

PH: 617-496-7548

FAX: 617-495-7490

Also, John Polizotti is the mechanical engineer who designed the MIRSI telescope interface mounting hardware:

[jpolizotti@cfa.harvard.edu](mailto:jpolizotti@cfa.harvard.edu)

PH: 617-495-7466

Boston University Institute for Astrophysical Research  
725 Commonwealth Avenue  
Boston, MA 02215

Postdoc Joe Adams

[jdadams@bu.edu](mailto:jdadams@bu.edu)

PH: 617-353-0285

FAX: 617-353-5704

Grad student Marc Kassis

[mkassis@bu-ast.bu.edu](mailto:mkassis@bu-ast.bu.edu)

PH: 617-353-0285

FAX: 617-353-5704

Also, Fiscal Administrator Kim Paci has handled MIRSI fiscal accounts

[kpaci@bu.edu](mailto:kpaci@bu.edu)

PH: 617-358-0603

FAX: 617-353-5704

## 1.3 Engineering vendor contacts

### Dewar Cryostat Design and Fabrication

Infrared Laboratories, Inc.  
1808 East 17<sup>th</sup> Street  
Tucson, AZ 85719-6505  
<http://www.irlabs.com>  
[irlabs@irlabs.com](mailto:irlabs@irlabs.com)

Elliot Solheid, Project Manager  
[esolheid@irlabs.com](mailto:esolheid@irlabs.com)  
PH.: 520-622-7074  
FAX: 520-623-0765

Kirby Hnat, Sr. Cryogenics Engineer  
[khnat@irlabs.com](mailto:khnat@irlabs.com)  
PH.: 520-622-7074  
FAX: 520-623-0765

### Electronics Box

Dr. Robert (Bob) Leach  
Astronomical Research Cameras, Inc.  
Dept. of Astronomy, MS 1221  
San Diego State University  
San Diego, CA 92182  
PH.: 619-594-1406  
FAX: 619-594-7454  
[leach@mintaka.sdsu.edu](mailto:leach@mintaka.sdsu.edu)

### Detector Issues

Dr. Steve Solomon, Raytheon Consultant  
Acumen Consulting  
P.O. Box 6084  
Santa Barbara, CA 93160  
PH.: 805-708-5084  
FAX: 8-5-683-2462  
[jwock@earthlink.net](mailto:jwock@earthlink.net)

Mr. Robert (Bob) Mills, Sr. Focal Plane Engineer  
Raytheon Electronic Systems, Infrared Operations  
75 Coromar Drive  
Bldg. B2, MS 8  
Goleta, CA 93117-3090  
PH.: 805-562-4064  
FAX: 805-562-2127  
[remills@west.raytheon.com](mailto:remills@west.raytheon.com)

Mount Design and Fabrication

Mount design & bipod fabrication

Mr. John Polizotti  
Harvard-Smithsonian Center for Astrophysics  
60 Garden Street  
Cambridge, MA 02138  
[jpolizotti@cfa.harvard.edu](mailto:jpolizotti@cfa.harvard.edu)  
PH: 617-495-7466

Mount fabrication

Mr. Robert (Bob) Vere, Project Manager  
Boston University Scientific Instrument Facility  
3 Cummington Street  
Boston, MA 02215  
PH.: 617-353-2614 or 617-353-5056  
FAX: 617-353-6021  
[vere@bu.edu](mailto:vere@bu.edu)

## 2. PREPARING MIRSI FOR AN OBSERVING RUN

### 2.1 IRTF contact info

**Hilo office:** Institute for Astronomy – IRTF  
640 N. Aohoku Place, #209  
Hilo, HI 96720  
808-932-2300  
FAX: 808-933-0737

**Manoa office:** Institute for Astronomy – IRTF  
2680 Woodlawn Drive  
Honolulu, HI 96822  
808-988-3893  
FAX: 808-988-3893

**Summit:** 808-974-4209  
FAX: 808-974-4212

**Shipping:** Attn: George Koenig (Hilo address)  
[koenig@irtf.ifa.hawaii.edu](mailto:koenig@irtf.ifa.hawaii.edu)  
808-974-4209

**Instrument interface  
and cryogen coordination:** Lars Bergknut (summit)  
bergknut@ifa.hawaii.edu  
808-974-4210

**Administration:** Karen Hughes (Manoa)  
Hughes@irtf.ifa.hawaii.edu  
808-956-6795

**Observing Requirements Form:** <http://irtfweb.ifa.hawaii.edu/userSupport/ORF.html>

**LHe orders and delivery:** Gaspro Hilo Mailing address: P.O. Box 30707  
Honolulu, HI 96820-0707

### 2.2 Cryogenics at IRTF

The MIRSI team is responsible for obtaining the appropriate amount of cryogenics at the IRTF summit. The expected amount of cryogen use should be determined well in advance of the run and entered into the Observing Requirements Form. In addition, contact Lars Bergknut directly and let him know of MIRSI's cryogenics plan.

IRTF will provide LN<sub>2</sub>, but the MIRSI team must specify the amount. The MIRSI team is responsible for ordering and scheduling the delivery of LHe to the summit. Place LHe orders directly with Gaspro Hilo (808-935-3341) *at least 10 days in advance* (because LHe is obtained from the mainland) and have them

deliver it to the IRTF on the summit of Mauna Kea. Currently, Gaspro delivers to the summit on Wednesdays. The IRTF staff can pickup LHe on other days, but Gaspro delivery is usually preferred. Also, expect to receive only 80% of the nominal LHe quantity due to boil off during transport. The storage boil off rate on the mountain is approximately 2 liters per day.

Note Fiscal Administrator Kim Paci (BU) has set up a BU account with Gaspro. If another account will be used to pay for cryogenics, it will have to be created.

## 2.3 Timescale guidelines

### = 3 months ahead of run:

Contact Lars Bergknut to:

- Discuss the instrument interface. Lars may request a drawing of the MIRSIS mount plate with the bolt hole pattern and orientation direction.
- Verify which IRTF cables will be available to link the camera system in the dome to the control room, such as fiber optic cable (150' length, w/ ST connectors), BNC cable, and serial cable (150' length). Expect to bring these cables to IRTF in any case as backups.

### = 1 months ahead of run:

- Determine cryogen quantities that will be used. Fill out Observing Requirements Form.
- Check that a Gaspro account exists to pay for cryogenics.
- Notify Lars of the cryogen plan so that he can obtain the LN<sub>2</sub> for the run and anticipate LHe delivery by Gaspro.

### = 10 days ahead of run:

- Order LHe from Gaspro for delivery (presumably for delivery on the Wednesday before initial cooldown).
- Pack MIRSIS cases and determine their weights (should be similar to previous weights in the past). Label cases and attach a copy of the airbill on each case.
- Ship MIRSIS to the IfA office in Hilo (Attn: George Koenig). NOTE: The Fedex heavyweight division does not deliver to Hilo, only Honolulu. Alternate carriers (e.g. Aloha Airlines Cargo) are available to deliver shipments from Honolulu to Hilo. Allow several days for the IRTF staff to bring the MIRSIS equipment up to the visiting instrument room on the summit.

### = few days ahead of run:

- Plan to arrive at Hale Pohaku a few days in advance of the run in order to become acclimated to the altitude and to unpack, pre-cool, and setup MIRSIS on the telescope. The camera setup procedure should be coordinated through Lars so that MIRSIS does not interfere with other IRTF projects.

## 2.4 Packing inventory and weight distribution

This has been a typical configuration for the MIRSIS equipment. Of course, the location of small, miscellaneous items will have to be adjusted to the distribution of available space. Weights will vary accordingly.

## Case 1 – 185 lbs.

dewar w/NW40 cap on vacuum valve and grounding caps on all mil-spec connectors  
snout  
rear electronics support bracket interface plate, bolted to dewar  
window cover

## Case 2 – 160 lbs.

SUN CPU case  
motor control box  
Leach power supply  
Leach electronics box w/50-pin open connector and 37-pin grounding connectors attached  
temperature controller  
chop drive box  
chop drive power cable

## Case 3 – 120 lbs.

computer monitor  
temperature monitor  
keyboard  
mouse  
DATAPROBE box  
DATAPROBE box power cable  
null modems (4 or more)  
extra 8-line serial cable spool  
4mm data storage tapes, <= 12 GB.

## Case 4 – 80 lbs.

JFET box, packed with foam  
power cables (~9 or more) (suggest label w/ green tape as MIRSI ID tag)  
latex hosing (small and large diameter)  
small stainless steel Funnel with fill tube  
25-pin serial cables (25' length) (2)  
flow meter – packed in bubble wrap  
cryo gauge - ”  
IRLabs fill tube w/ vent port – ”  
extender board, packed in cardboard box  
portable socket set:  
small socket ratchet  
socket driver  
long and short ratchet extenders  
incl. 7/16” socket  
cryo glove pairs (2)  
inflatable bladders (2)  
cable ties  
dewar window baffle

### Cables

tape drive to PC  
PC to video monitor  
fiber optic cable pair (100') (2), packed in cardboard box  
fiber optic cable pair (30'), ”  
spare fiber optic cable pair (3'), ”  
motor drive  
signal  
clocks  
home switch  
temp. monitor  
temp. controller  
ethernet  
serial – PC A port (25-pin) to DATAPROBE input null modem  
serial – gray – DATAPROBE output null modem to motor box (9-pin)  
serial – gray - DATAPROBE output null modem to temp. controller (8-pin modular)  
serial – brown - DATAPROBE output null modem to temp. monitor (8-pin modular)  
temp. and home switch cable pigtail  
motor cable pigtail  
BNC cable for chop signal out (25')  
9-pin male-to-female extension cable, for extender board  
37-pin male-to-female extension cable, ”

## Case 5 – 180 lbs.

### Mount

bipods (3)  
bipod feet shims (6)  
electronics support bracket

1/2-20 bolts, nuts

1/20 flat & lock washers

1/4-28 bolts

1/4 flat washers

1/4-20 lock nuts

3/8-16 bolts, nuts

3/8 flat & lock washers

mount block screws & pins

1/4-20 nylon brushings

1/4 nylon spacers

### Documentation

MIRSI Operating Manual

MIRSI log sheets

MIRSI lab notebooks

MIRSI minutes &  
correspondence

Raytheon array test data

Raytheon CRC-774 manual

IRLABS dewar manual +  
cooldown data for new  
dewar

Phytron motor & box  
manuals

MIRSI Leach controller

Leach board schematics

A/D, FIFO data sheets

Lakeshore 208 & 321  
manuals

OMS control board manual

Voodoo software manual

FITS manual

### Tools

hex key sets (2)

hex ball driver set

long 9/64" hex ball driver

jewelry screw & socket  
drivers set

wire cutters (lg. & sm.)

needle nose pliers (lg. & sm.)

adjustable wrench

calipers

tape measure

electric drill

wire-stripping tool

wire strippers

crimping tool

exacto-knife & blades

razor

retaining ring pliers

phillips & flat head drill bit  
set

drill bit set

long & short tweezers

wire wrap-stripping tool

IC extraction tool

dental tools

mechanical fingers

### Miscellaneous

small flashlight

latex gloves

Kim wipes

Polystyrene calibration cards

wood screws

### Vacuum & Cryo

vac. gauge (optional)

vac. gauge meter (optional)

8-line cable for meter  
(optional)

ambient temp. sensor, wire &  
pins

NW40/25 tee connector

NW40 to 25 cone adapter

NW40 to 25 straight adapter

NW25 to nozzle adapter

NW25 clamps (4)

NW40 clamps (2)

NW25 blanks (4)

NW40 blank (1 on dewar, 1  
extra)

NW25/40 plastic covers

NW25/40 O-rings (2-4 each)

pipe thread to thin nozzle  
adapter

pipe thread to wide nozzle  
adapters

teflon tape

transfer line O-ring fittings

hose clamps

extra latex tubing

### Electrical

electrical tape

DMM

DMM wires

DMM leads needle-tipped

DMM leads alligator-tipped

DMM wires, socket- & pin-  
ended

small bread board

bread board wire

MIRAC User's Manual  
mount drawings  
wiring diagrams:

JFET box  
clock & signal cables  
temp. & motor cable  
motor control boards  
chop driver board  
electronics box &  
connectors  
dewar connectors

foil tape  
duct tape  
packing tape

Extra dewar hardware

8-32 cap screws (1")  
4-40 cap screws  
2-56 cap screws  
4-40 flat head screws,  
1/4", 3/16", 1/8"  
plastic washers for fill ports

wire wrap wire  
coax wire (26 AWG) spool  
red/black wire (26AWG)  
spools  
assorted resistors and caps  
spare J500 JFETS  
anti-static wrist straps w/clips  
gender benders, 9- & 25-pin  
extra null modems  
plastic mil-spec connector  
covers  
fiber optic connector covers

**Case 6 – 90 lbs.**

mount plate, packed with foam

**Case 7 – 40 lbs.**

LHe transfer lines (2)  
NW25 vacuum connector to evacuation valve

**2.5 Suggested shipping crate labels and orientation markers**

Here are some labels that have been attached to the MIRSI shipping crates.

**CASE 1**

**CASE 2**

**CASE 3**

**CASE 4**

**CASE 5**

**CASE 6**

**CASE 7**

**CASE 8**

**CASE 9**

**↑ UP ↑ UP ↑ UP**



**THIS SIDE UP**

## 3. SETTING UP MIRSI

### 3.1 Unpacking and inspection

MIRSI should be unpacked and inspected upon the observing team's arrival. Open the crates, and look for any possible damage. Lay components out neatly on the tables in the visiting instrument room. If there is any damage, notify the present senior person.

*In particular, unpacking requires:*

- Open the CPU case, and ensure that the boards, wires, connectors, drives are secured. Be sure that there are no loose screws floating in any of the computer device cases.
- Open the Leach electronics box. Gently reseal all boards and connectors, even if they visually appear secure.

### 3.2 Host Computer

Unpack the host PC computer. Before power up, please open the CPU case and look for loose boards, cables, wires, or free-floating screws, etc. Also, inspect the monitor for possible damage. *These quick checks will help to prevent irreparable damage to the computer if something became amiss during shipping.*

Once the host PC is booted, connect it to the network by doing the following (or just run the script described below):

- Log in as root.
- Make copies of, then edit the files: `/etc/hostname.hme0`  
`/etc/defaultrouter`  
`/etc/nodename`  
`/etc/inet/hosts`  
`/usr/local/rsi/license/license.dat`

to accommodate the new network information, which should be available from the observatory.

A script called **setupnet.scr** is found in **/home/root**. This script will copy pre-existing files for a given network setup with suffix as hostname. For example,

**setupnet.scr insguستا**

will copy the network files used at IRTF (for hostname insguستا), `/etc/hostname.hme0.insguستا`, etc. to `/etc/hostname.hme0`, etc. Currently, network files exist for host names **mirsi** (BU), **insguستا** (IRTF), and **mlof5** (Mt. Lemmon). These names can be used as input arguments for the **setupnet.scr** script.

After setting up the network files,

**reboot**

as root. There may be some long pauses during boot, but once the machine is fully booted, it should have network access. When MIRSI returns to the BU lab, run

`/home/root/setupnet.scr mirsi` as root.

## 3.3 System Check

Ideally, once the host computer is running and is on the network, the operability of the electronics, array, and filter wheels should be verified. Doing so allows any problems to be identified and corrected before the dewar is cold.

### 3.3.1 Electronics

After the Leach electronics boards are reseated, check the operability of the electronics by connecting the 37-pin grounding plug to the box. Leave the 50-pin clocks connector open (don't short!) This will produce a "zero" signal. Follow the instructions for connecting the electronics to the host PC described in §3.7.1, and for taking images described in §4 (but load the timing file `/home/camera/software/SOURCE/zerolevel/tim.lod`). The electronics should cooperate with the commands given by the host computer. Take a few images, the level should be around 65,000 counts or so (this corresponds to "zero" level due to an internal sign flip in the signal).

### 3.3.2 Array

Next, remove the 37-pin grounding plug from the Leach box and connect the Leach box to the dewar as described in §3.6. Be sure the **Camera Power On** is *deselected* in the software (or better still, that the electronics are powered off). Do the source follower gain (SFG) test (§3.7.2) to be sure the array multiplexer is working. The SFG will be slightly lower when the array is warm.

## 3.4 Dewar evacuation using vacuum pump

The procedure for pumping the dewar down to high vacuum is also described in the IRLabs Boston University manual. MIRSI uses a turbo-molecular pump, backed by a conventional mechanical pump.

- Open the cold shutter.
- Connect the dewar vacuum valve to the vacuum pump. In the lab, you can use the NW40-NW25 tee connector to adapt the Edwards vacuum gauge to the (typically) NW40 pump line. Connect the gauge forward of the turbo pump!
- Leaving the dewar valve closed, begin pumping and evacuate the vacuum line, usually until the turbo pump is running nearly full speed.
- Slowly open the dewar valve. There may be a slight hissing due to evacuation of gas in the dewar, depending on whether the dewar was initially under vacuum. Very slowly continue to open the valve in small steps. When hissing stops, usually after several minutes, open the valve fully, and continue pumping overnight, or least several hours if the dewar was initially under a good vacuum.
- When the dewar reaches sufficiently low pressure ( $10^{-5}$  to  $10^{-4}$  Torr), first close the dewar valve, then turn the pump off. After the pump winds down, vent the pump line and disconnect the pump line from the dewar valve.
- Attach the NW-40 safety cap blank to the mouth of the dewar valve.

- Close the cold shutter, then disengage the pivot shaft.

## 3.5 Cooldown

The procedure for cooling the dewar is also described in the IRLabs manual for the Boston University dewar. When observing, fill MIRSI with LN<sub>2</sub> once per day at the end of the night. Fill with LHe every 36 hours, if possible; otherwise fill with LHe at the end of each night.

### 3.5.1 Pre-cool

- First, connect the LN<sub>2</sub> storage dewar to the LN<sub>2</sub> reservoir using a latex-type hose and the IRLabs fill tube. Be sure the reservoir can vent gas without obstruction. Then slowly begin LN<sub>2</sub> flow into the reservoir. Once liquid begins collecting, it should take 15 – 20 minutes to fill the reservoir (assuming the storage dewar pressure is at the nominal 22 psi; a smaller storage dewar at lower pressure will take longer).
- Repeat for the LHe reservoir using LN<sub>2</sub>. This reservoir takes 30 – 60 minutes to fill.
- After a few hours, top off the LN<sub>2</sub> reservoir. Attach boil off hoses to prevent ice plugs from forming in the fill port necks. Allow the dewar to cool to 77 K overnight, or if pressed for time, at least 6 hours.

### 3.5.2 LHe cooldown

- When pre-cool is completed, measure the level of LHe in the storage dewar.
- Pump out the LHe transfer line if it has not been pumped out recently.
- Blow out the LN<sub>2</sub> in the LHe reservoir.
- Insert gradually a LHe transfer line into the storage dewar. After a few minutes, liquid should be visible exiting the transfer line.
- Immediately insert the transfer line into the LHe fill port, keeping the tube as far down as possible without obstructing the venting gas.
- The temperature of the cold surface should start dropping within a minute or two. Once liquid starts to collect in the reservoir, the venting plume should decrease noticeably, and the temperature should drop rapidly to below 10 K.
- The pressure in the LHe storage dewar should be kept at 1 –3 psi. If the pressure drops below this level, pressurize it by cycling warm He gas into the storage dewar using the inflatable bladder or cylinder of GHe.
- The reservoir will fill up in 30-40 minutes, liquid will begin to shoot out of the fill port – remove the fill line immediately, depressurize the storage dewar, and remove the fill line.
- Measure the LHe level in the storage dewar, and record results in the MIRSI cryo log.
- The hold time for this initial fill should be 12 – 18 hours. Once the LHe transfer is completed, top off the LN<sub>2</sub> reservoir.
- Attach the flow meter to the LHe fill port and mount to the dewar appropriately. Attach the boil off hose to the LN<sub>2</sub> fill port.

## 3.6 Mount

- Attach the interface plate for the electronics support bracket before shipping MIRSI.
- Attach the electronics support bracket to its interface plate on the dewar using ¼-28 hex-head bolts and ¼ flat washers.
- Attach the Leach electronics box to the electronics support bracket. Use 2 nylon spacers on each PEM stud against the box surface. Insert a nylon bushing is inserted where the PEM stud goes through the bracket, with the flat part flush along the top of the bracket. Secure the PEM studs with ¼-20 lock nuts.
- Attach the upper bipods to the mount plate using the ½-20 bolts and lock washers.
- Use a mechanical lift to bring the mount plate and bipods up to the MIM interface. Bolt the mount plate to the MIM using the asymmetrical bolt hole pattern with ½-20 bolts and lock washers. The directional orientation should be marked on the plate, if not, refer to drawings for correct orientation.
- Use the mechanical lift to raise the dewar up to the lower bipods. Be sure the small mount block is attached and pinned to the dewar between the fill ports. Attach the dewar to the bipods using ½-20 bolts and lock washers.

## 3.7 Camera Electronics

**WARNING: Always use anti-static mats and grounding straps whenever touching the electronics box or dewar connectors and cables.**

### 3.7.1 Electronics setup

The electronics should be set up using the following procedure:

- After unpacking, open the Leach electronics box and reseal all boards and connectors.
- Connect the Leach power supply to the Leach electronics box.
- Connect the electronics box to the host PC using a dual fiber optic cable.
- Connect the chop signal from the electronics box to the chop drive box using a fiber optic cable. At IRTF, the nod signal is left open; the host program sends nod commands to the telescope control system over the network.
- Connect the 37-pin readout signal cable to the Leach box and secure.
- Connect the 50-pin clocks cable to the Leach box and secure.
- Connect the readout cable to the JFET box.
- Remove the 41-pin grounding connector from the dewar.
- Connect the JFET box to the dewar.
- Remove the 61-pin grounding connector from the dewar.
- Connect the clocks cable to the dewar.

## 3.7.2 Source Follower Gain test

If running the detector chip for the first time since shipping, the MIRSI observing team should perform the source follower gain (SFG) test. The SFG test measures the response of the readout system from the pixels to the host PC by manipulating an artificial signal on the pixels. The detectors are “turned off” during this measurement (which allows the measurement to be made when the detector is at room temperature as well as LHe temperature).

**WARNING: This test should only be performed by a trained MIRSI team member. No guest observer should ever change the array voltages without explicit guidance from a team member.**

- Boot the host software
- Load the timing file `/home/camera/software/SOURCE/clkvrstuc/tim.lod`
- Take a few images and note the overall level of counts
- From the **Setup** menu, open the **Bias and Clock Voltages** window and select the one on the **Clock Voltages LOW** column for **VRSTUC**. Enter `-2.5` and press **Update Selected**.
- Take a few more images. The counts should increase by several thousand, depending on the designated range of the A/D converters (usually `0 → -5 V`) set in the timing source code. Note the response is usually best at LHe temperatures.
- Now, update **VRSTUC (LOW)** to `-3`. Take a few images. The counts should increase by a similar amount (i.e., there should be linear response with changing **VRSTUC LOW**).
- The SFG can be calculated using the following formula:

$$SFG = DV_{out}/DV_{in}$$

Where  $DV_{out} = N_{adu} \cdot AD\_RANGE / (65535 \cdot LEACH\_GAIN)$  and  $\Delta V_{int}$  is the change in **VRSTUC (VRSTUC HIGH – VRSTUC LOW, or `2V - VRSTUC LOW`)**. The **AD\_RANGE** is typically `5 V`, and the **LEACH\_GAIN** is `2`. The SFG is specified at roughly `0.6`. Thus, a change in **VRSTUC** of `0.5 V` should produce a signal swing of about  $N_{adu} \approx 13,000$  counts. If the **AD\_RANGE** is `10 V`, the swing will be about `6,000` counts.

- If the SFG test is successful, turn the camera power off. If the camera is cold (`4 K`), follow the instructions for operating the camera in observing mode (will require loading a different timing file).

## 3.8 Motor Control System

MIRSI contains three cryogenic stepper motors, fabricated by Phytron, to turn the filter and aperture wheels. The components used to drive the motors are housed in the Phytron motor control box. This box contains three SINCOS current drivers (that turn the motors), which are controlled by an Oregon Micro Systems (OMS) “intelligent” control board. The OMS board communicates with the host PC over an RS-232 serial line, computes the position, velocity, and acceleration profiles for motor motion, and sends the pulses to the SINCOS drives. Here are the steps to set up the motor control system:

- Briefly open the motor control box and inspect for loose boards and wires.
- If disconnected, connect the MIRSI host computer serial port A to the DATAPROBE breakout box. There should be a null modem on the DATAPROBE master port.
- Connect DATAPROBE 25-pin output A to a null modem (A), then the null modem to the OMS control board 9-pin input connector, located in the Phytron motor control box.
- Plug the four motor drive cable connectors into the Harting connectors at the rear of the motor control box. Currently, the fourth connector is attached to a spare cable.
- Connect the motor drive cable pigtail output to the 32-pin connector on one of the dewar’s feet (next to the vacuum valve).
- Connect the four motor control cables to the dewar at the pigtail. The connectors should be color-coded. Ensure that the cable is stress relieved.
- Plug the home switch/temperature sensor pigtail cable into the 46-pin connector on the dewar.
- Connect the home switch cable from the 25-pin output on the rear of the motor control box to the appropriate color-coded pigtail connector.
- Ensure that the motor control box power switch is off, and then connect the power connector to a standard power outlet.

**WARNING:** *Note when the motor control box is initially powered on, the motor currents are by default on, and this rapidly heats the inside of the dewar and boils off precious LHe and observing time. Turn the motor currents off by immediately executing the INIT command from the host software (see §4).*

## 3.9 Temperature Control

### 3.9.1 Setup

MIRSI currently contains four silicon diode temperature sensors made by Lakeshore Cryogenics: one on the rear of the cold finger which cools the detector; one on the upper rear of the detector fanout board near the MDM connections; one on the interior lip of the 77 K shield near the back plate (where the optics box

can be opened); and one similarly on the interior of the floating shield. These sensors provide precision temperature measurements. To read these sensors, the set up steps are the following:

- Connect the Lakeshore 321 temperature controller cables from the “housekeeping” color-coded pigtailed cable to the controller’s 6-pin sensor input and dual BNC jack for the heater output current. The LOW side of the BNC connector is marked.
- Connect the Lakeshore 208 temperature monitor’s 25-pin input to the pigtailed cable using the temperature monitor cable.
- Connect the pigtail to the dewar’s 26-pin connector. As usual, all cables should be stress relieved.
- Install power cables on the controller/monitor to standard power outlet.
- If disconnected, connect the 25-pin serial port A on the host PC to a null modem on the DATAPROBE input port.
- Connect the 8-line gray serial line between the controller’s serial I/O port to a null modem (C) attached to output port C on the DATAPROBE breakout box.
- Connect the 8-line brown serial line between the controller’s serial I/O port to a null modem (B) attached to output port B on the DATAPROBE breakout box.
- Power on the controller and monitor and verify that the sensors are reading the expected temperatures.

### 3.9.2 Operation of temperature controller

A Lakeshore temperature controller reads the temperature of the sensor on the rear of the cold finger. The controller also has a 2-pin current output, which is connected to a heater (resistor) on the rear of the cold finger. The controller allows closed-loop temperature control using the sensor and the heater, or can simply be used as an open loop temperature sensor. To use the closed-loop mode, select **Set Point**, enter the desired temperature, and press **Enter**. Then press **Heater Low** or **Heater High**. For open loop mode, press **Heater Off**. MIRS currently operates in the open loop mode, so the heater power is usually off. See the Lakeshore 321 *User’s Manual* for further information.

### 3.9.3 Operation of temperature monitor

A sensor temperature reading is selected by manually cycling through the eight available channels on the monitor using the CHANNEL button. Currently, the channels utilized are:

1. Detector fanout board, rear side
2. 77 K shield
3. Floating shield

See the Lakeshore 208 *User’s Manual* for further information.

### 3.9.4 Temperature log

The host software contains a program that automatically cycles, reads, and records all temperatures at regular intervals. To start this program:

- Boot the host software

- From the Session menu open the **Temperature Control** window
- Select **Active**.
- The program will automatically create a temperature log for that date (or append to an existing one) in the ASCII file `/home/camera/TemperatureLogs/log_YYYYMMDD`. Alternatively, a log file name can be manually entered.

## 3.10 Telescope

At IRTF, the day crew will prepare the telescope at the beginning of the run for observations with MIRSI.

### 3.10.1 Secondary mirror

The appropriate secondary mirror (chopping secondary,  $f/35$ ) should be installed and cleaned by the day crew. MIRSI should not be mounted on the telescope during this procedure (to save cryogenics), unless necessary.

### 3.10.2 Balance

Once MIRSI is cold and mounted with all components and cables secured on the telescope, the telescope should be weight balanced by the day crew.

## 4. OPERATING MIRSI

This procedure contains the steps for taking an exposure once the dewar has been pumped out, cooled down, and has reached a stable operating temperature.

1. Open the cold shutter.
2. Remove the window cover.
3. Turn on the Leach power supply. Two green LED lights in the rear of the Leach box should indicate that the power is on. If no LED lights are on, see the Troubleshooting Guide.
4. Power on the Utility Electronics (Temperature monitors and Chop Driver Box) if they are not operating.
5. Start the software:
  - Log in as camera
  - Synchronize the UT time with the telescope if they are not within your tolerances by typing **xclock –digital –update 1 &** and correct using the UNIX **date** command as root.
  - From an open shell tool or xterm, start the image display program using the command **ds9 &**  
then start the camera host software with the command **mirsi**  
This starts the MIRSI user interface and image display software.
6. If the power on the stepper motor electronics is cycled or being turned on for the first time, follow these instructions.
  - Power on the stepper motor electronics.
  - Immediately initialize the motors:
    - Open the: **Observing Commands (Observing Parameters)** window under the **Session** pull down menu
    - Press the **INIT** button near the bottom of the window.

REASON: When the motors electronics are turned on, the motor currents are active. The motor currents add 3 W inside the dewar and will evaporate 16 L of He in a few hours.
7. Start or continue the temperature log by opening the **Temperature Control** window under the **Session** menu. Select **Active**.
8. From the **Setup** menu, open the **Observing Setup** to setup the electronics for the observing session. A pop up window will request you to check the temperatures. After the YES button is selected, the **mirsi** shell window should report a **done** for each of the selected tasks in the **Controller** window. If the shell reports that errors have occurred, try running the Observing Setup a couple of times. See the troubleshooting guide for tricks to make it work if the problem persists.  
  

REASON: The electronics will sometimes boot in an unusual state which requires time for the DSPs to reset.
9. Open the **Observing Parameters** window.
  - Click on the **Observing** button.
  - Select **Home All Wheels**

- Press the **Move** button. The **Move** button should morph into **Stop**. When the wheels have reached their home positions, the **Move** button will appear again. Once the wheels are homed, they do not need to be homed again unless the motor control box loses power or the wheel position becomes incorrect for some reason.
  - Choose an initial filter and Press the **Move** button to rotate the wheels.
10. From the **Observing Parameters** window,
    - Select **DCA before Power On**.
    - Select **Camera Power On**.
    - Select appropriate observing parameters and press the **Apply** button.
  11. Power on the detector: Select Set Detector Voltages from the Setup menu. Answer **Yes** to the warning if the camera is cold (4 K).  
This option sets the correct voltages from the the **Bias and Clock Voltages** window:

**WARNING:** Do not apply these voltages when the camera is warm (> 15K). Doing so will induce large currents through the detectors, and could damage them.

<b>VCASUC</b>	-3.5
<b>VDETGRV</b>	-7.3
<b>VGATE (HIGH)</b>	-4.0
<b>VGATE (LOW)</b>	-7.3

Note: These voltages require reapplication after each time the camera issues a **Camera Power On** command. The best value for **VDETGRV** was determined to be where the signal-to-noise peaks as a function of **VDETGRV**. The bias voltage across the detectors is  $VGATE\_HIGH - VDETGRV - V\_thresh$  where  $V\_thresh$  is a diode threshold across the gate, about 1.3 V.

**PROBLEM:** Sometimes the software does not set the values and instead does nothing. If when you expose, you observe sky levels of ~10,000 counts no matter what frame time is set, reapply the Set Detector Voltages.

12. From the **Session** menu, open the **Target & Observer Info** window. Select the site and enter the observer and target object information.
13. From the **Display** menu, select the desired display mode (difference, pattern remove, coad, tile, single).
14. In the main window, click **Expose** to start an exposure. Note: **DO NOT Abort** during an exposure, only between multiple exposures. If **display image** is selected, then when the exposure is finished, **mirsi** will automatically display the image in the ds9 window, in the selected display mode. For multiple exposures, **mirsi** will automatically display each image after acquisition.

# 5. OBSERVING WITH MIRSI

## 5.1 Telescope interface at IRTF

### 5.1.1 Sending commands to the Telescope Control System

The MIRSI host software can send commands directly to the IRTF telescope control system over the network. The IRTF program **tcsio** is used for this task. **tcsio** is installed on the host PC in the directory **/usr/local/bin**.

Some sample commands with **tcsio** are:

<b>tcsio ABEAM</b>	Nod to beam A.
<b>tcsio BBEAM</b>	Nod to beam B.
<b>tcsio ra_offset_(asec) dec_offset_(asec) OFFSET</b>	Send arcsecond offsets to the telescope.
<b>tcsio 0 0.0 0.0 1</b>	Zero offsets

The nod beams are by the telescope control system. For more information, see the telescope operator or other IRTF staff member.

### 5.1.2 Chopping

The chop throw is set by IRTF staff. At IRTF, chop rates should be tuned to avoid resonance frequencies of the secondary mirror (8 – 9 Hz or so). The IRTF chopper should be set to Ext (External) when using MIRSI.

Larger chop throws require large chop waits.

When in chop mode, the MIRSI electronics generate a binary chop signal bit from the Leach timing board (pin named H4, otherwise known as STATUS0). This chop signal is buffered on a separate chop drive board and converted to an optical signal by an LED source. The optical signal is carried outside the Leach box by fiber optic cable to an independently powered chop driver box. The chop driver box converts the optical signal into a TTL signal with BNC output. A BNC cable should be used at the IRTF to carry the signal from the driver box to the chop bit input of the telescope control system.

When chop mode is selected in the MIRSI host program, the timing software will automatically control the beam switching using the chop bit. Chop rates are limited by the speed of the array readout. The host program will convert the desired chop parameters into integer frame readouts, and display the updated results accordingly when the **Apply** button is pressed.

### 5.1.3 Nodding

Nod throws are set by the IRTF staff.

At the IRTF, telescope nod is controlled over the network using the **tcsio** program (see §5.1.1). The host software automatically uses this command between exposures to nod the telescope. The nod beams are defined using the telescope control system. The commands **tcsio ABEAM** and **tcsio BBEAM** nod the telescope to the respective beam.

Note the chop driver box has a nod bit that is directly analogous to the chop bit. The host software sends a command to the timing board to set or clear the nod bit before an exposure. This nod signal is used at Mt. Lemmon, but not at the IRTF.

### 5.1.4 Collimation

To collimate the optical beam, first close the mirror covers and open the hatch so that the secondary mirror sees the mirror covers, and the camera is looking at the secondary. Fine-tune the dewar's pointing by slowly loosening the bolts on the bipods to tip/tilt the dewar. When the signal is maximum, measure the gaps between the dewar and the bottom surface of the bipods using calipers or a micrometer. Create shim spacers by peeling away layers on the bipod feet-shaped shims until the shims are the correct thickness. Disconnect the dewar from the bipods, place the shims between the bipods and the dewar, then bolt the dewar back to the bipods.

Next, point the telescope at a bright star and defocus the star to a “doughnut” or ring shape as seen by the camera. Have the telescope operator adjust the tilt of the secondary mirror until the ring appears uniform in brightness.

### 5.1.5 Target lists

Target information is gathered by the host program and entered into the image FITS headers. Currently, the host program does not yet send coordinates to the telescope control system. The host program can upload a file containing a list of targets or coordinates. This feature speeds up the process of updated the target information into the FITS header. A target file requires the form

Object\_name RA DEC Epoch  
e.g. (note the underscore in the name string):

Orion\_nebula 05:05:50 +05:30:29 2000

To load the target list, first from the **Session** menu select **Target & Observer Info**, and then load the file. Alternatively, an observer can enter the target information manually, and optionally add the target to the current list.

## 5.1.6 Standard stars

For point source flux calibration, the MIRSI team typically uses bright targets from a list of mid-infrared standard stars in the *MIRAC3 User's Manual* (W. Hoffmann & J. Hora 1999).

## 5.1.7 Telescope offsets and dither/mosaic procedures

Telescope offsets can be sent from the MIRSI host software to the telescope control system. Under the **Session** menu, open the **Offset Commands** window. Manually enter the offsets (in arcsec) and press the **Send** button.

To load an automated, 4-step dither pattern, choose tiny (1"); small (10"); medium ("); or large (60"). A custom dither pattern of an arbitrary number of steps can be created in a file with 2 columns of offset, e.g. **example.off** (Note the last two rows are 0.0 0.0):

```
-5.0 0.0
-5.0 5.0
0.0 10.0
0.0 -5.0
5.0 5.0
10.0 0.0
0.0 0.0
0.0 0.0
```

and subsequently uploaded by the host software. The directory for offset files is currently **/home/camera/Offsets**.

Automated mosaic patterns are available as 2×2, 3×3, or 4×4 field patterns. The current default field-of-view is 60". There is an option to load a custom mosaic file analogous to a custom dither file.

Once the observing parameters and dither and/or mosaic patterns are specified, simply click **Expose** to start the sequence, then sit back, relax and enjoy the show.

## 5.2 Log sheets

The following sheets were created to assist in the planning, execution, and documentation of MIRSI observations and cryogen usage. The Observing Plan sheet is optional, but please use the setup, observing log, and cryogen log sheets whenever observing with MIRSI.



# MIRSI SETUP

**Date UT** \_\_\_\_\_ **Data directory** \_\_\_\_\_  
**Site** \_\_\_\_\_ **Gain** \_\_\_\_\_ e-/ADU **Readout noise** \_\_\_\_\_ e- **Pixel scale** \_\_\_\_\_  $\alpha$ /pix  
**FOV** \_\_\_\_\_  $\text{arcmin}$  **Chop wait** \_\_\_\_\_ ms **Nod wait** \_\_\_\_\_ s **Linear range 0 -** \_\_\_\_\_ ADU  
**Notes:** \_\_\_\_\_

File No.	Time UT	$\lambda$ ( $\mu\text{m}$ )	Frame time (ms)	Chop freq (Hz)	Sky level (ADU) (Blank subtract)	Overhead Ratio (total time / on-source time)	Comments
		Blank					
		2.2					
		4.9					
		7.8					
		8.7					
		9.8					
		N-band					
		10.3 MLOF					
		11.6					
		12.282					
		12.5					
		18.5					
		20.9					
		25.9					
		CVF short					
		CVF mid					
		CVF long					
		Grism 7-14					
		Grism 18-26					





## 6. END OF RUN TASKS

Here is a check list for necessary tasks at the end of an observing run. Mostly, the shutdown procedure is simply the reverse of the setup procedure. It will take three people about two hours to complete these tasks.

1. In the host software, deselect the **Camera Power on**.
2. Home the all three filter wheels.
3. Exit the host software.
4. Backup all data onto tape and/or a remote machine.
5. Install the dessicant trap.
6. Power down the Leach power supply.
7. Power down the motor control box, temperature controller, and temperature monitor.
8. Don wrist strap.
9. Remove clocks cable from the dewar.
10. Install a grounding cap on the dewar's 61-pin clock signals connector.
11. Remove the signal cable from JFET box.
12. Remove the JFET box from the dewar.
13. Install a grounding cap on the dewar's 46-pin readout signals connector.
14. Disconnect all cables from the Leach box and insert the 37-pin shorting plug in the 37-pin readout signals connector on the Leach box.
15. Disconnect the fiber optic cables for the Leach electronics and the chop/nod driver box. Coil and safely set aside the fiber optic cables.
16. Disconnect the temperature controller cable, temperature monitor cable, home switch cable, and motor drive cables and pigtails on both sides. Set all cables aside.
17. Insert grounding plugs into the 26-pin housekeeping and motor drive connectors on the dewar.
18. Disconnect all power cords from the peripheral components.
19. Disconnect the serial lines and connectors between the host PC and the DATAPROBE box, and between the DATAPROBE box and the peripheral components.
20. Dismount the Leach power supply, chop drive box, temperature monitor, temperature controller, motor control box, and DATAPROBE box.
21. Dismount the dewar.
22. Dismount the Leach box from the electronics support L-bracket.
23. Unscrew the electronics support L-bracket from the dewar. Leave the interface plate attached to the dewar.
24. Remove the flow meter and hoses, and blow out remaining cryogens in the dewar.
25. Unbolt the mounting plate from the telescope and remove.
26. Remove bipods from the mounting plate.
27. Halt the host PC.
28. Disassemble the host PC, monitor, tape drive, keyboard, and mouse.
29. Pack the crates with care.
30. Label the crates under the same airbill.
31. Notify George Koenig that MIRSI is ready to be shipped. The IRTF staff will haul the cases down to the IfA Hilo office.
32. After George confirms MIRSI is in Hilo, contact Fedex and have them come and pick up the shipment at the IfA Hilo Office.

# APPENDIX

This appendix contains check lists for MIRSI setup, nightly tasks, a troubleshooting guide, and wiring diagrams for major electrical additions and/or “rebuilding” jobs.

## **CHECK LIST FOR MIRSI SETUP**

1. Unpack the camera. Be sure the dessicant trap is attached and the cold shutter is open during vacuum pumpout. Bring the camera into the prep room (the room containing the vacuum pump and cryogenes).
2. Open the other crates and inspect the contents for damage.
3. Unpack the temperature monitor, temperature controller, and associated cables. Connect them to the dewar and ensure the temperature sensors are reading appropriate values. Begin recording temperatures.
4. If time permits, unpack the host computer. Check for loose parts, and adjust if necessary. Boot the host computer and connect to the network.
5. Again, if time really permits, connect the serial interface to the host computer and to the temperature monitors/controller. Boot the host software and begin the temperature log. Otherwise, temperatures can be recorded manually in the MIRSI lab notebook.
6. Connect the dewar vacuum valve to the vacuum pump. Begin pump out.
7. Check that the (L-shaped) mount electronics support bracket interface plate is attached to the dewar (optics box face).
8. Attach the electronics support bracket to its interface plate.
9. Attach the Leach electronics box to the electronics support bracket.
10. Open Leach box and reseal all boards and connectors.
11. When the dewar reaches sufficiently low pressure ( $10^{-5}$  to  $10^{-4}$  Torr), first close the dewar valve, then turn the pump off. After the pump winds down, vent the pump line and disconnect the pump line from the dewar valve. Attach the NW-40 safety cap to mouth of the dewar valve.
12. Close the cold shutter, then disengage the pivot shaft.
13. During pump out and/or pre-cool, the day crew can install the appropriate secondary mirror for MIRSI (chopping secondary).
14. Begin pre-cooling with LN<sub>2</sub>. Allow for pre-cooling overnight if possible.
15. After pre-cool, blow the LN<sub>2</sub> out of the LHe reservoir. Immediately begin LHe fill.
16. Attach the mount bipod legs to the mount/telescope interface plate.
17. Attach the mount/telescope interface plate to the MIM.
18. Attach the dewar to the mount bipods (assuming LHe fill is completed).
19. Attach the flow meter to the LHe fill port and mount to the dewar appropriately.
20. Mount the leach power supply box onto the MIM.
21. Rack-mount the peripheral components onto the MIM: motor control box, temperature monitors/controller, chop drive box.
22. Connect power and signal cables to all components. Stress relieve the cables.
23. Connect fiber optic cables to the camera electronics, and the chop drive box. Stress relieve carefully.
24. Set up the MIRSI host computer and connect to the network, if not done already. Boot the host software and verify that the temperature, filter wheel motors, and camera electronics are functioning properly.
25. Balance the telescope.

## **MIRSI NIGHTLY OBSERVING CHECK LISTS**

### **General Startup**

1. Be sure camera and cables will be free of obstruction during telescope motion
2. Open cold shutter
3. Turn on Leach box power
4. Remove dessicant trap
5. Start host software (if not already running)
6. Check motor currents off by pressing the **INIT** button in the host software.
7. Restart Temperature Log if inactive
8. Update UT date-labelled data directories, if necessary
9. Set UT date – run **xclock –digital –update 1** and update using UNIX **date** command as root.
10. Select Observing Setup, Power on , Set detector voltages in this order
11. Take a few images. If a few channels are bad, see the Troubleshooting Guide.

### **Shutdown**

1. Camera power off from host software.
2. Leach box power supply off.
3. Leave MIRSI program up and keep temperature log active.
4. Attach dessicant trap – window cover.
5. Close cold shutter.
6. Measure LHe level in storage dewar & determine the time for the next fill.
7. Fill the dewar cryogen reservoirs as necessary.
8. Measure storage LHe level again; record results in cryo log.
9. Backup data onto tape and/or remote machine.

*MIRSI Operator's Guide*  
**MIRSI TROUBLESHOOTING GUIDE**

The MIRSI system sometimes exhibits a few strange problems that require on-the-fly adjustments to the system. The “solutions” to some of the problems are often superstitious in nature (less than 100% guarantee that they will work) but seem to have worked in the past for some known or unknown reason.

**1.No power on-indicating LED lights illuminated on the rear of the Leach box and PCI board:**

Power down the Leach box, and reseal the Leach power cable connectors at both ends.

**2.Host software issues fail warnings during application of controller reset and timing file download:**

Press the white reset button a few times. If that is unsuccessful, recycle power on the Leach box a couple of times. Eventually, these tricks will work.

**3.Absence of photo-signal in an exposure:** If the multiplexer is reading out correctly (source follower gain test is successful), but there is no photo-signal in an exposure, check for one or more of the following steps:

- Detectors have been turned on (must occur every time array is powered on).
- Cold shutter is open.
- Aperture wheel is sitting at the imaging or a slit position.
- Both filter wheels are sitting on a filter and long wavelength blocker/open position (i.e., no AI blank is in the optical path).
- Frame time is sufficiently large enough for given filter.

**4.Certain channels exhibit radically different zero levels than the other channels:** Usually this occurs at the beginning of the night, when the electronics are first powered up. Try the following, which work best after the electronics have been powered on for **5 – 10 minutes**:

- Power down the array by deselecting “Camera power on”.
- Power on the array by selecting “Camera power on”.

If that doesn't work, try:

- Power down the array by deselecting “Camera power on”.
- Power down the Leach box.
- Wait 10 seconds, then power the Leach box back up.
- From software, follow the usual steps to reset the controller and power up the array.

If that doesn't work, try:

- Power down the array by deselecting “Camera power on”.
- From a shell tool or xterm, type **cd /home/camera/software/SOURCE/choptest/custom**.
- Using your favorite text editor, edit the file **waveforms.asm** by changing the parameters OFF\_0,...,15, e.g., the channel offsets should read something like:

<b>OFF_0</b>	<b>DC</b>	<b>\$0c0000</b>
<b>OFF_1</b>	<b>DC</b>	<b>\$0c4100</b>
<b>OFF_2</b>	<b>DC</b>	<b>\$0c8200</b>
<b>OFF_3</b>	<b>DC</b>	<b>\$0cc300</b>
<b>OFF_4</b>	<b>DC</b>	<b>\$1c0400</b>

OFF_5	DC	\$1c4500
OFF_6	DC	\$1c8600
OFF_7	DC	\$1cc700
OFF_8	DC	\$2c0800
OFF_9	DC	\$2c4900
OFF_10	DC	\$2c8A00
OFF_11	DC	\$2ccB00
OFF_12	DC	\$3c0C00
OFF_13	DC	\$3c4D00
OFF_14	DC	\$3c8E00
OFF_15	DC	\$3ccF00

- Save the file, then from the window, type **tim**. The timing file should compile.
- Reset the controller and download the new timing file. Follow the usual steps to power up the array.
- Restore the offset levels in **waveforms.asm** to the usual values (last three digits of OFF\_0, etc. are usually **500**). Power down, reset, reload, and power up again.

There is no guarantee that these tricks will work at all.

**5.Chop and/or nod differenced images exhibit a noise pattern that affects faint signals:** The bad news is the noise is persistent and difficult to remove for extended sources over the whole array. The good news is for point sources, the noise can be filtered by e.g. subtracting the median level of the set of pixels that are in the same location in every channel.

**6.One or more channels reads a railed ADU value of 65535:** Usually this means the signal is disconnected before it reaches the A/D converter (the A/D converter outputs a railed value for an open input). Try powering down the electronics, and then reseal the signal cable connectors. If the disconnected signal is persistent, it must be found by checking the connectivity of the signal chain from the detector pins to the A/Ds. *Only a MIRSI team member should perform this procedure*, since it can put the array, and the rest of the electronics, at risk.

**7.Host software freezes:** The best way to solve this problem is prevention. Overloading the **mirsi** program with commands while the program is performing a task can lead to paralysis of the program. If the program does freeze up, try the following in sequential order until one works:

- Press the reset button on the PCI card (white button on the PC near fiber optic connectors) a few times.
- Power down the Leach box. If this is successful at freeing the program, exit the program, and then power everything up in the usual order.
- If both of the above are unsuccessful, power down the Leach box, then power down the PC. Obviously, this poses a risk to both the array and the PC file systems.

**8.Slow LHe fill and/or condensation and frost on transfer line:** The LHe transfer lines are prone to loss of vacuum in their insulating jackets. Pump out the transfer line for a few minutes. If the problem persists after pump out (such behavior has been known), use another transfer line.

*MIRSI Operator's Guide*

**9.LHe-cooled work surface suddenly heats up to above 7 K:** A *sudden* increase in the temperature of the work surface may indicate one of the following problems:

- LHe reservoir is depleted - refill.
- Motor currents have been left on. To turn them off, immediately press the **INIT** button in the host program.
- Vacuum leak in the dewar. Other symptoms of a vacuum leak include condensation and frost present on the exterior of the dewar. If the latter symptom is present, blow out the cryogen and put the dewar on the vacuum pump.
- Stage heater is running.

## TIMING SCHEME CONCEPT, EXPOSURE PARAMETERS, AND IMAGE ACQUISITION TIME

This section of the Appendix contains concept diagrams for the MIRSI global detector timing scheme and the calculation of total exposure time for a given set of frame parameters. MIRSI's timing scheme incorporates aspects of both Raytheon timing schemes: Integrate-then-read, and Integrate-while-read. The beauty of the CRC-774 Readout Integrated Circuit (ROIC) is that it can be operated in several different ways, depending on the needs of the user. The timing scheme for MIRSI currently consists of a "non-destructive" readout (NDR). This entails a global reset of the array (all pixels addressed and set to their reset value), followed by integration (**VGATE** toggled to its high value). During integration, the multiplexer is clocked (rows and pixels addressed in the usual sequence), but the pixels are *not* reset in order to keep the photo-charge integrating. After an integer number of clock cycles have occurred (i.e., the frame time), **VGATE** is toggled to its low value to halt the integration. In the subsequent clock cycle, the rows are addressed in sequence as usual, but the pixels are reset and read out with A/D conversion and coadding processes. After a specified number of these frames (coadds), the image is transmitted from memory on the coadder boards to the host PC.

Between exposures, the multiplexer is clocked continuously without integration using an idle clock cycle (global reset, followed by row clocking and pixel reset without integration and A/D conversion). In chop mode, these idle frames are taken between chop levels, while the secondary mirror moves between its alternate beams.

The chop high and chop low image buffers are stored in separate memory buffers in the coadder boards' SRAM memory and transmitted to the host PC as a single, large image.

The characteristic times are (drawings not to time scale):

### Expose frame:

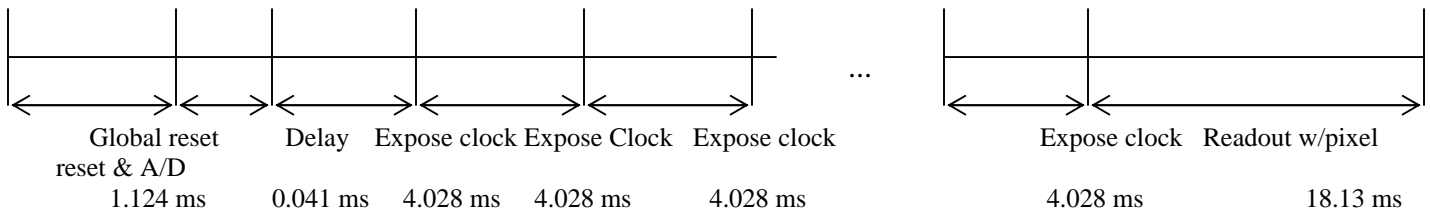

### Idle frame:

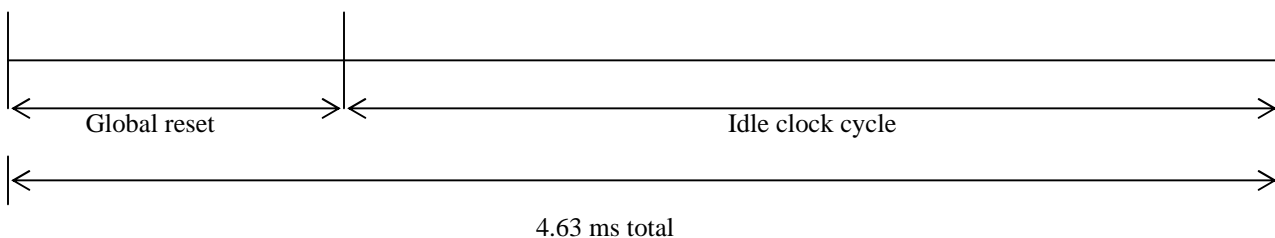

Chopping pattern:

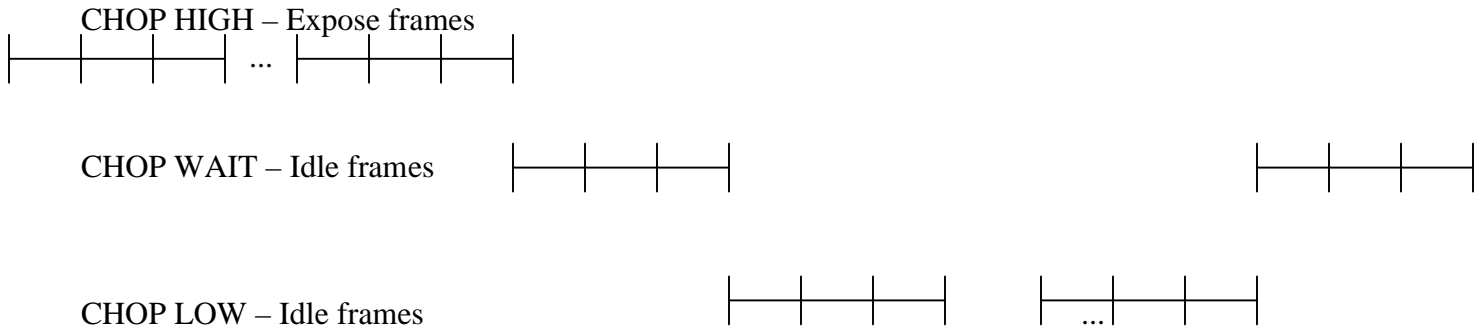

The frame and chop parameters can be set from the host program using the following manual DSP commands:

**SNC** – Set number of coadds for the exposure.

**SET** – Set exposure time, i.e. the frame time in integer number of expose clock cycles.

In grab mode, the total on-source time is determined by  $N_{coadd} \cdot Frame\_time$ . The total acquisition time is determined by  $N_{coadd} \cdot (Frame\_time + Global\_reset + Post\_reset\_delay + Readout\_time)$ .

**SCC** – Set chop command (0 = grab mode, 1 = chop mode).

**SFC** – Set frames per chop, number of frames on-source per chop cycle.

**SCW** – Set chop wait, number of idle frames clocked between chop levels.

**SNL** – Set nod level (0 = beam A, 1 = beam B), sets DSP nod bit to desired level (not used at IRTF).

From this scheme, the total amount of time to acquire the exposure can be calculated. Since the frames are readout out in integer numbers, the exact value of acquisition time and chop parameters will be the sum of integer frame times (expose and idle). The **mirsi** host program makes these calculations when the user enters the observing parameters. A portable program, **mpars.c**, is available in **/home/camera**. This program can be compiled using the UNIX command **gcc -o mpars mpars.c**. Afterwards, type **mpars** to see the usage options.

The programs first compute the number of frames per chop:

$$SFC = \left[ \frac{1}{2(Chop\_frequency)} - SCW \times Idle\_frame\_time \right] / Total\_frame\_time$$

where  $Total\_frame\_time = Frame\_time + Global\_reset + Post\_reset\_delay + Readout\_time$ . The total acquisition time is then:

$$Total\_acquisition\_time = \left| \frac{2 \times N\_coadd \times (SFC \times Total\_frame\_time + SCW \times Idle\_frame\_time)}{SFC} \right|$$

and the total on-source time is still  $N_{coadd} \cdot Frame\_time$ .

The controller has only modes for grab and chop. The host program has the controller treat a nod set like two separate exposures. Thus, when in nod mode, the acquisition time is double the grab or chop

*MIRSI Operator's Guide*

acquisition time. The host program then writes a nod set as a single FITS file with up to 3 FITS extensions.

*MIRSI Operator's Guide*

## SYSTEM TAPE BACKUP

To backup the MIRSI host PC, use a 12 GB 4mm DAT tape (20 GB is too large). There is a **backup** script to assist with the system tape backup procedure in **/home/root/backup**. The directories to be backed up include **/home**, **/opt**, and **/mirsi1**. If space permits, also backup **/mirsi2**. To run the script,

- Log in as root.
- Type **cd /home/root/backup**
- **ls** to see the date of last backup.
- Check the MIRSI lab notebook for that date to see which tape, A or B, was used, and insert the alternate tape (if funding allows, a better scheme is to use a new tape for each backup date).
- Edit the **backup** script to include **/mirsi1** and/or **/mirsi2** depending on data backup status and space available. Edit the e-mail address in the script where the notification message is sent.
- Type **./backup**
- The backup script will start and automatically backup the desired directories, save and gzip the backup file names in a file called **/home/root/backup/backup.YYMMDD.gz**, notify the user by e-mail when completed, rewind, and eject the tape.
- Make a note in the MIRSI lab notebook that the system was backed up onto tape (identify tape by A/B, date, or whatever).



MIRSI Operator's Guide

CONTROLLER BOX  
DB-50 Female

CLOCK DRIVER BOARDS: DB-37 Female  
CLOCK DRIVER #0      CLOCK DRIVER #1

1	IMUX	1	:	
2	VGG2	2	:	
3	VGG3	3	:	
4	VGG4	4	:	
5	VDETGRV	5	:	
6	VDETGRNG	6	:	
7	VNEG	7	:	
8	VCASUC	8	:	
18	VRSTUC	9	:	
19	VSHPCHG	10	:	
20	VSH	11	:	
21	VDDD	12	:	
22	VDD4	13	:	
23	VSSD	14	:	
24	VSS1	15	:	
25	VSS2	16	:	
34	VPW	17	:	
35	VCLOUT	18	:	
36	VCLCOL	19	:	
37	VSUB: wired to Vdd1, Vdd2, & Vdd3	33	:	not attached
38	VCAP	34	:	
39	VOFFSET	35	:	
40	VEN2TO1	36	:	
10	CLOCK GROUND	22	:	not attached
26	DC BIAS GROUND			22 : not attached
12	ROWSTRT	1	:	
13	RRESTRT	2	:	
14	RCLK1	3	:	
15	RCLK2	4	:	
16	ROWEN	5	:	
17	RSTROW	6	:	
28	CLCOL	7	:	
29	VGGCL	8	:	
30	SH	9	:	
31	SHPCHG	10	:	
32	CLOUT	11	:	
33	VGATE	13	:	
45	VGG1	14	:	
46	COLSTRT	15	:	
47	CCLK1	16	:	
48	P2TO1	17	:	
49	CCLK2	18	:	
50	P1TO2	19	:	
42	OUTPUT BIAS	35	:	not attached
11	CLOCK SHIELD	23	:	
27	CLOCK SHIELD	24	:	
44	CLOCK SHIELD	25	:	

DB-9 Male

1 & 2	20	:
4 & 5	21	:
6-9	22	- 25 :

## JFET current source box

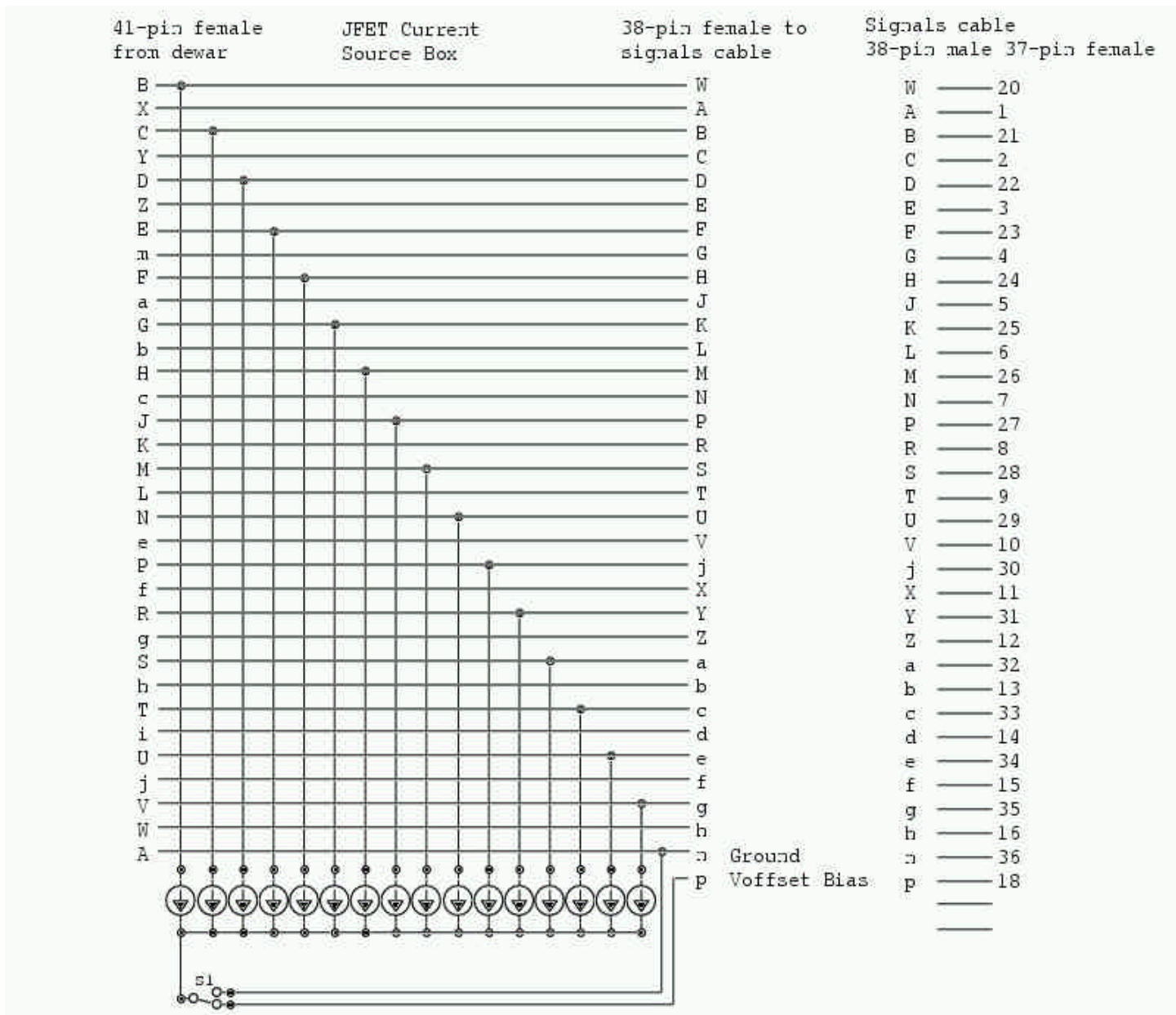

# MIRSI Operator's Guide

## Peripheral components

DEWAR SIDE  
ITT/Cannon  
32 pin connector  
MS3116F18-32S

4 Amphenol  
4 pin connector  
97-3101A-14S-  
2P  
w/ stress relief  
97-3057-1007

4 Amphenol  
4 pin connector  
97-3106B-14S-  
2S  
w/ stress relief  
97-3057-1007

4 Harting  
8 pin connectors  
Han D 7 pin male  
insert  
Hoods:09.20.003.042  
0  
Strain Relief: Olflex  
Cable –  
S2311(SLEX11W/N  
UT)

PHYTRON BOX

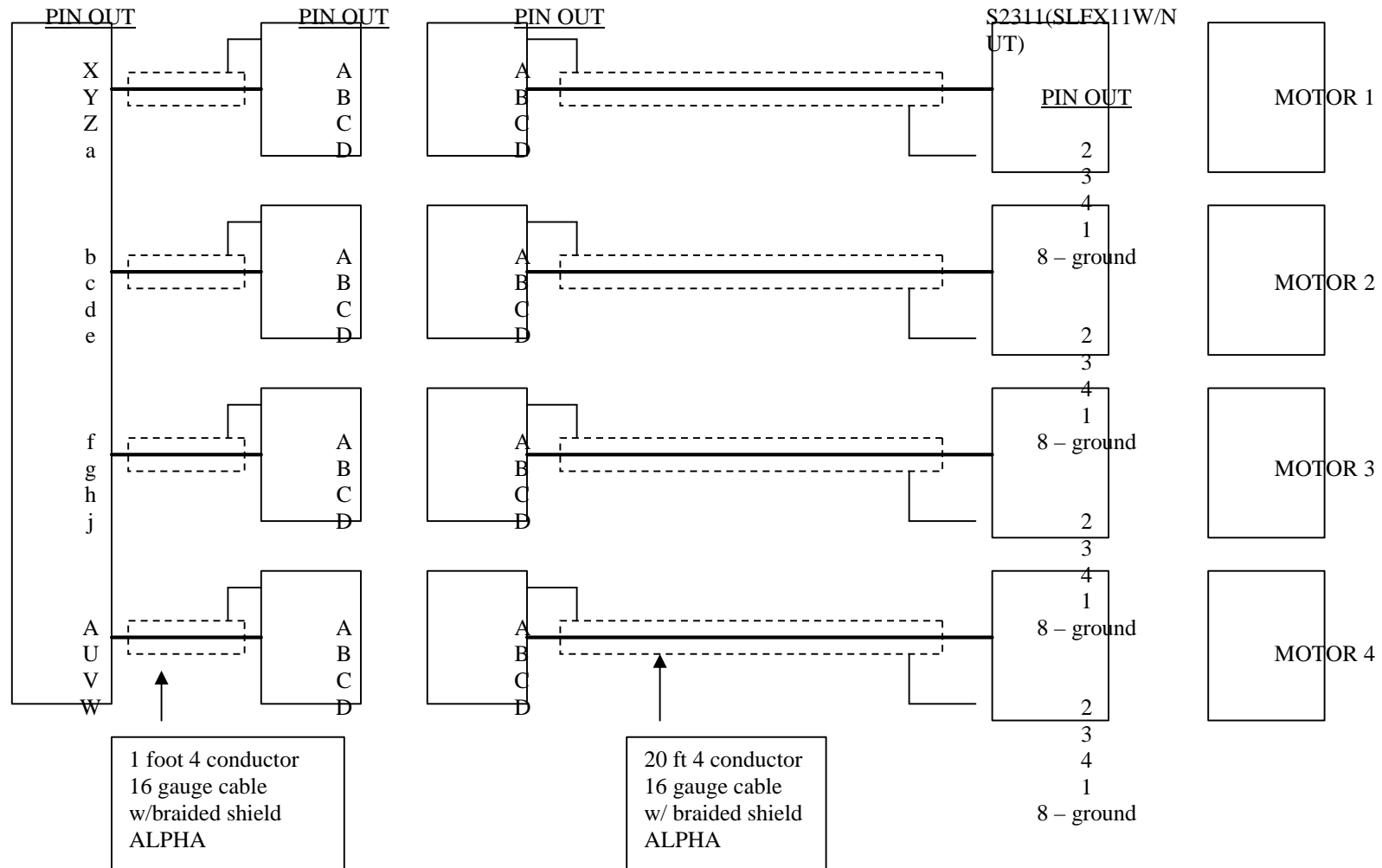

*MIRSI Operator's Guide*



*MIRSI Operator's Guide*

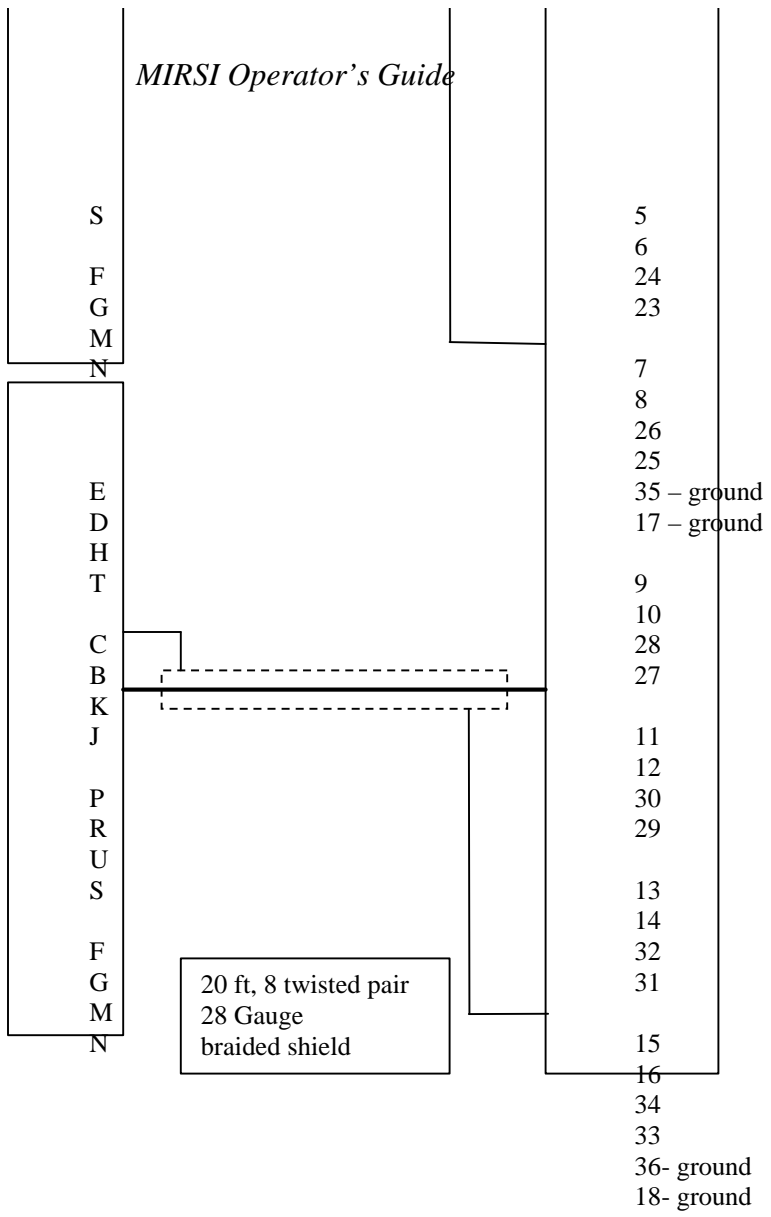

MIRSI Operator's Guide

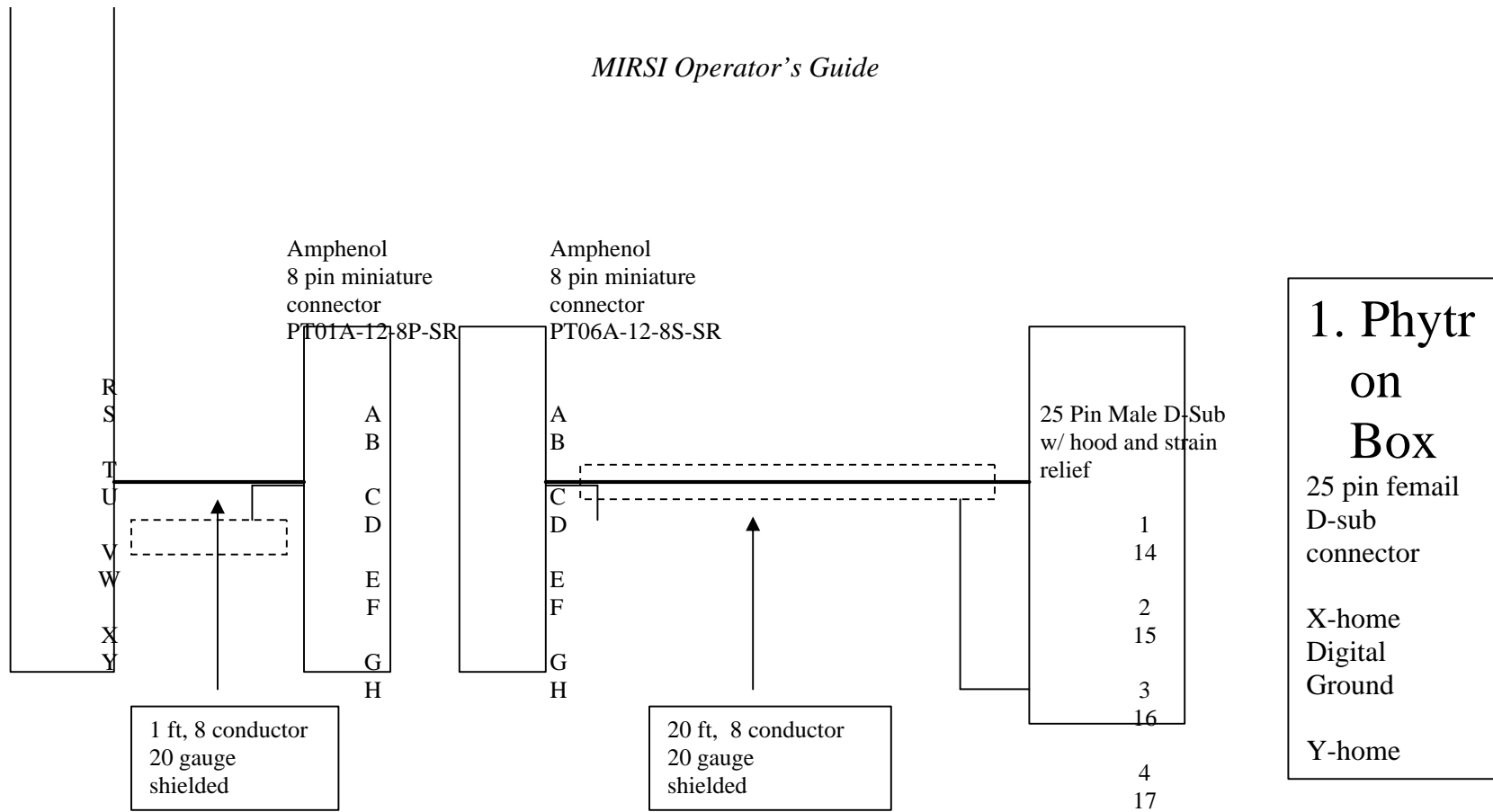

# MIRSI Operator's Guide

Wiring diagram on the OMS board.

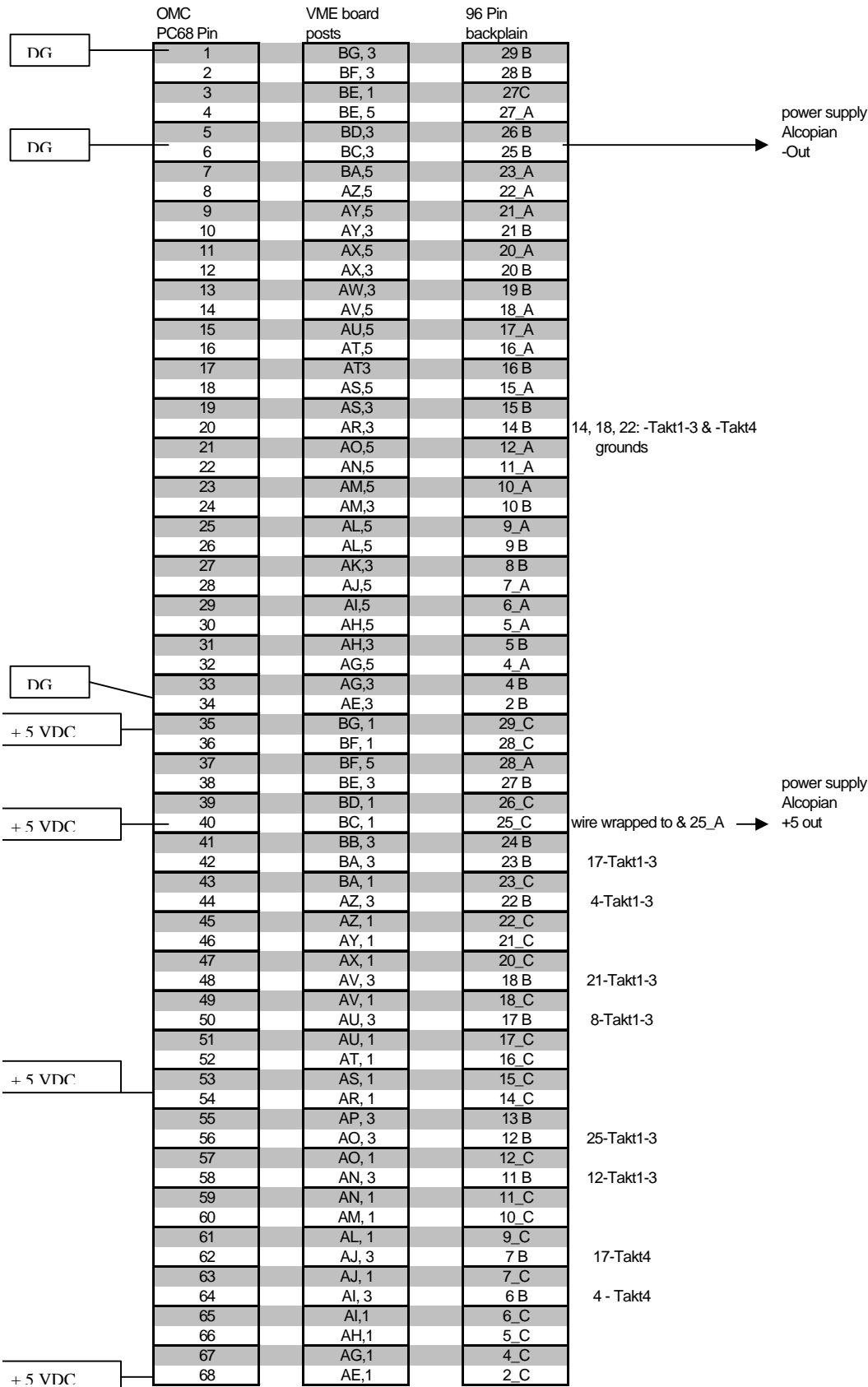

# Chop driver board

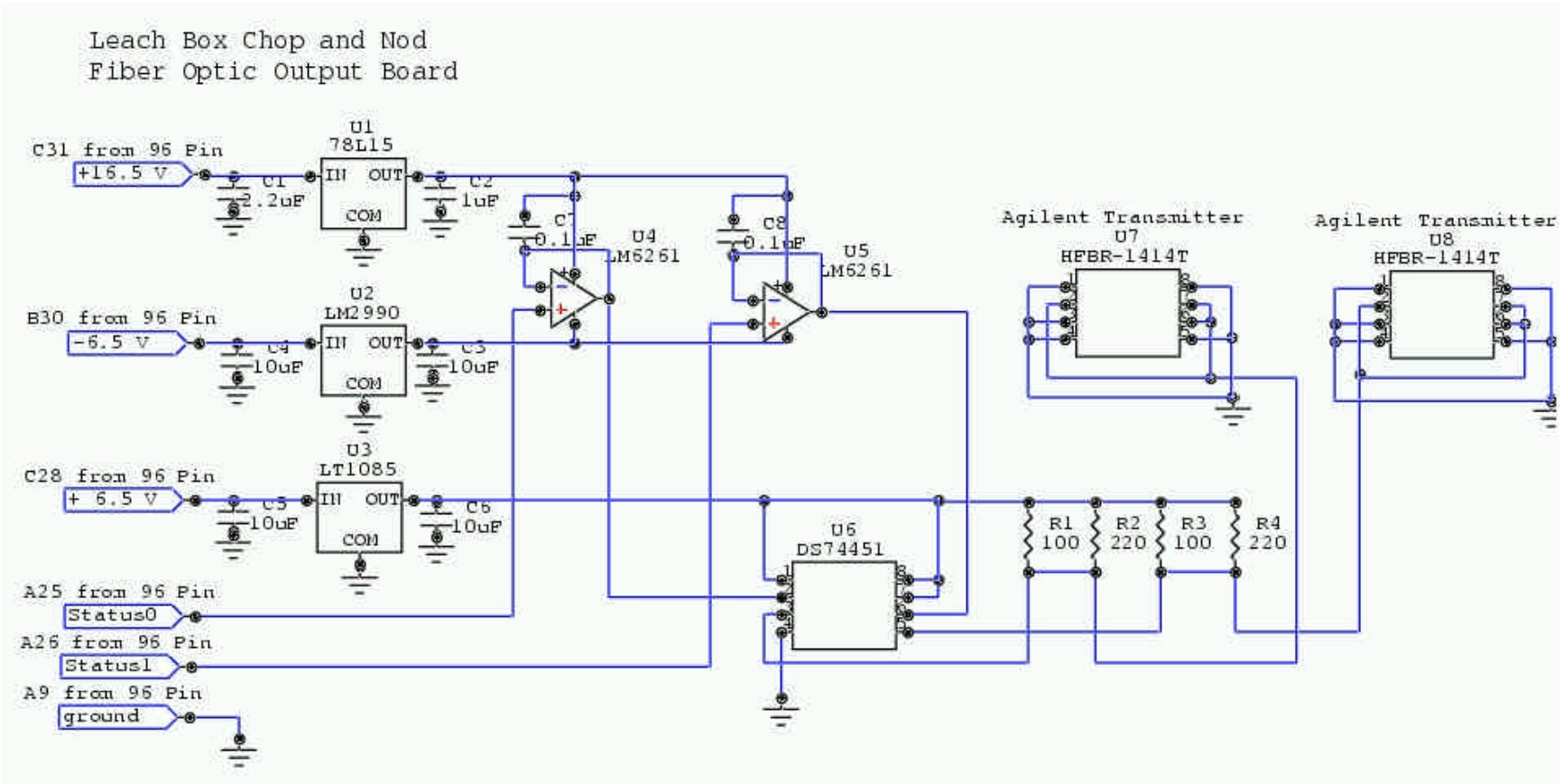

# BNC chop box

