

Wide-field CCD imager for the 6.5m MMT telescope

Brian McLeod
Daniel Fabricant
John Geary
Andrew Szentgyorgyi

Smithsonian Astrophysical Observatory
60 Garden St., Cambridge, MA 02138

ABSTRACT

The conversion of the Multiple Mirror Telescope from six 1.8m mirrors to a single 6.5m mirror will significantly increase its capability for imaging. The f/5 configuration will provide a corrected field of view for imaging that is flat and 30 arcminutes in diameter. The image quality in the absence of atmospheric seeing is $0''.1$ over the full field. We are currently designing a camera system to take advantage of this large field. The proposed direct imaging system will be located at the Cassegrain focus of the telescope, behind a three-element refractive corrector. We will use an array of 8x4 three-edge-butttable CCDs, each with 2048x4096 pixels and two output amplifiers. This will provide a field of view of $24' \times 24'$. With a new packaging scheme we will reduce the gap along the readout edge to a few millimeters. The pixel size is 15 microns, or $0''.09$, well sampling the point-spread-function. In many applications it will be possible to bin the pixels, thus reducing the amount of data (500 Mb per read at full resolution). The back-illuminated CCDs will be thinned and anti-reflection coated to provide high quantum efficiency from 320 to 1000 nm. The camera system will be useful for many studies requiring both a large collecting area and large area coverage on the sky. Planned projects include redshift and photometric surveys of faint galaxies, searches for high-redshift quasars and searches for objects in the outer solar system.

Keywords: CCDs, imaging, astronomy, telescopes, cameras

1 INTRODUCTION

The Multiple Mirror Telescope (MMT), located on Mt. Hopkins, Arizona, is currently being converted from six 1.8-m mirrors to a single f/1.25 6.5-m mirror. The new telescope will have several secondary mirrors, allowing a variety of applications. The f/5 focus of the 6.5-m MMT will provide a unique capability for wide-field imaging and spectroscopy among new large telescopes. A multi-object spectrograph (Hectospec) with 300 optical fibers and a 1° diameter field of view is currently under construction.¹ The imaging configuration of the wide-field corrector optics will deliver $0.1''$ FWHM images over a 30' diameter field. We describe here plans to construct a mosaic of CCDs to take advantage of this large field. Such a camera will be useful for numerous projects, among them faint galaxy redshift surveys, and searches for high-redshift quasars, supernovae, and small planets in the outer solar system.

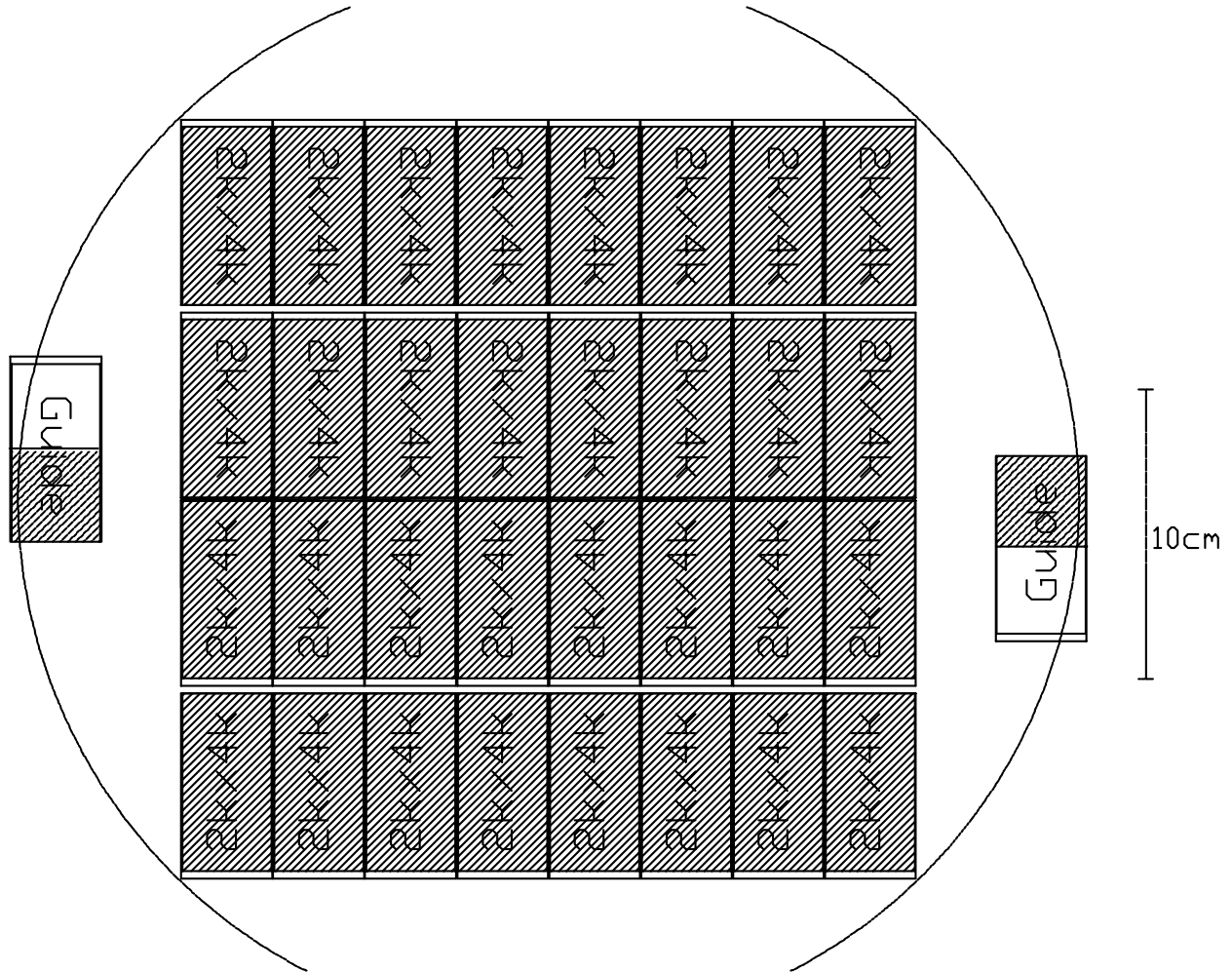

Fig. 1.— Schematic diagram of the focal plane. The circle represents a 35' diameter field. The CCDs cover an area of $24' \times 24'$.

Figure 1 shows the layout of the CCDs in the focal plane. Each of the 32 CCDs has 2048×4096 $15\mu\text{m}$ pixels. A pixel subtends $0.087''$ on the sky so the full mosaic covers an area $24' \times 24'$. The gaps between the CCDs will be less than 1mm, except along the readout edge where the gap will be 5mm. The CCDs will be anti-reflection-coated, thinned devices and as such will have excellent quantum efficiency from 3200\AA to 9000\AA . Each of the CCDs will have two output amplifiers, and we anticipate that the electronics will be able to read out the entire mosaic in 30 seconds. In many applications it will be desirable to bin the pixels at the time of readout, decreasing the readout time, and the amount of data that has to be stored. At full resolution, the mosaic will generate 512Mb of data on each readout.

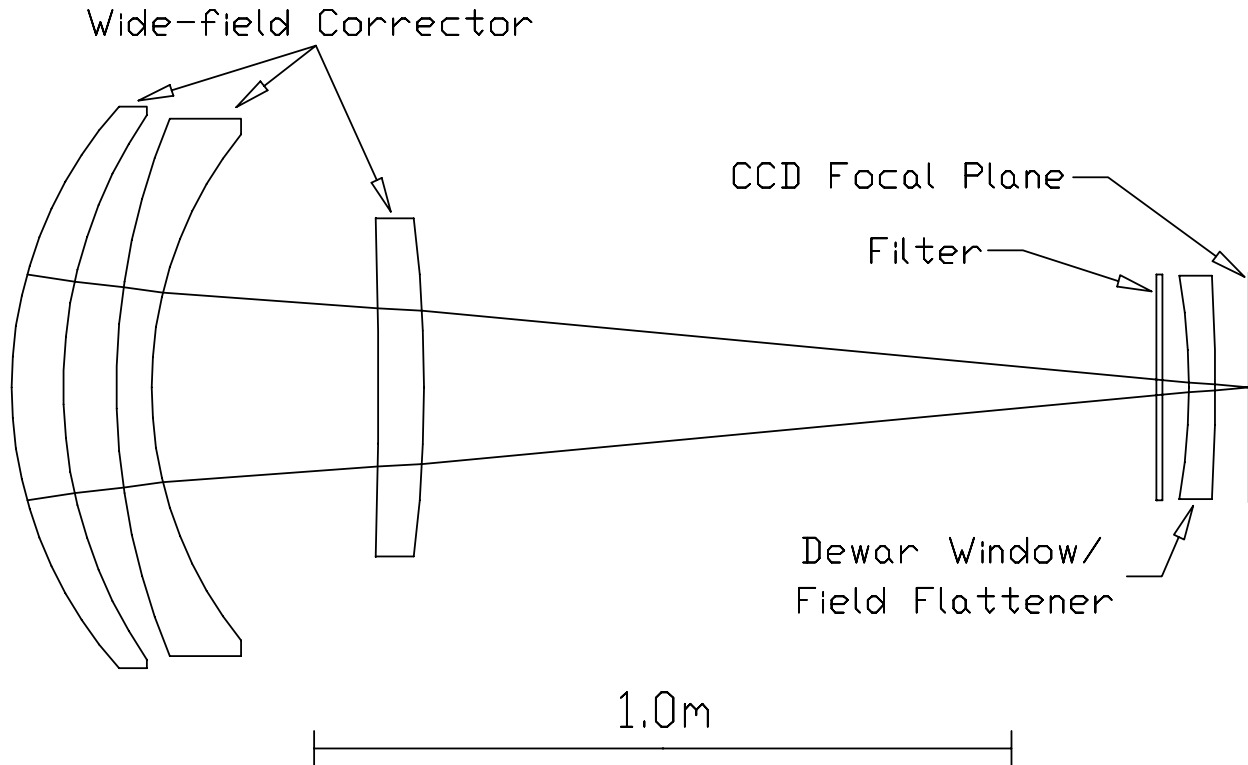

Fig. 2.—: Layout of the optics

2 INSTRUMENT DESCRIPTION

2.1 Optics

The optics feeding the CCD consist of the 6.5m primary and f/5 secondary of the MMT, a three-element refractive corrector, a filter, and a field-flattener (see Figure 2). Construction of the corrector,² which is also used by the Hectospec, is in progress. The first two elements of the corrector are larger to accommodate the 1° field of the spectroscopic configuration. The third element of the corrector is interchangeable to switch between the two configurations. The filters and field flattener will be constructed as part of this effort. The entire configuration has been optimized by Harland Epps at Lick Observatory to produce images with FWHM < 0.1'' over a 30' diameter field (see Figure 3). The focal plane is flat, making the mounting of the CCDs straight-forward. Distortion at the outer edge of the field approaches 1% however, precluding the use of this instrument in a drift-scanning mode. This compromise was made to keep the image quality high over the full field, thus taking full advantage of the good seeing on Mt. Hopkins.

2.2 CCDs

The CCDs will be 2048 × 4096 thinned three-edge-butable devices with 15μm pixels. Each of the chips has two output amplifiers. To minimize the area lost on the fourth non-butable edge, we are developing a new CCD package. Current packages have the leads and connector extending out horizontally from the CCD. Figure 4 shows a sketch of a candidate scheme. The silicon substrate is epoxied to an Invar mounting plate. A ceramic

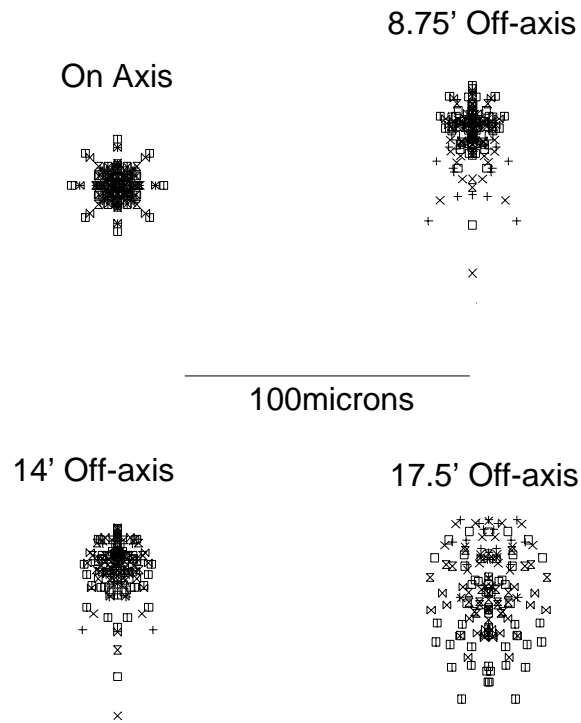

Fig. 3.— Spot diagrams for the MMT wide-field imaging optics showing wavelengths from 0.33 to 1.0 micron. The RMS image diameters over the full wavelength range are 13, 22, 21, and 31 microns, at 0, 8.75, 14, and 35 arcminutes off axis, respectively. A final tweaking of the optical design will further improve these numbers.

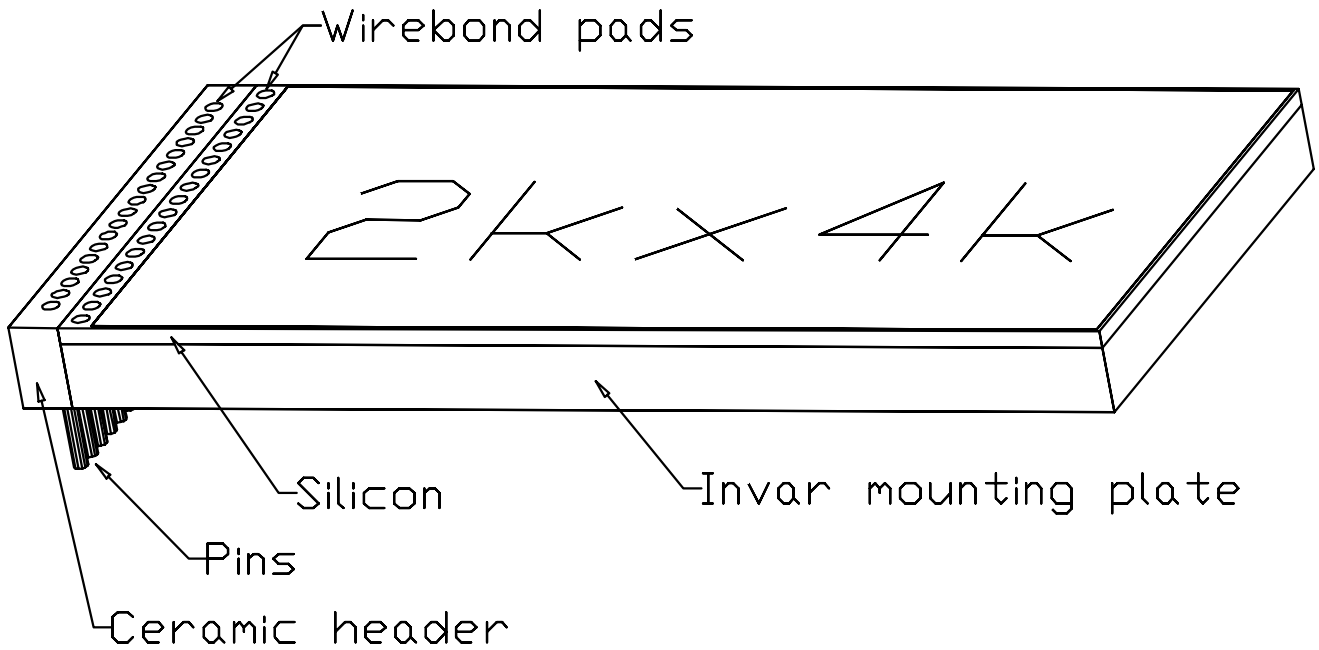

Fig. 4.— New packaging scheme to reduce the required spacing on the fourth edge of the CCD.

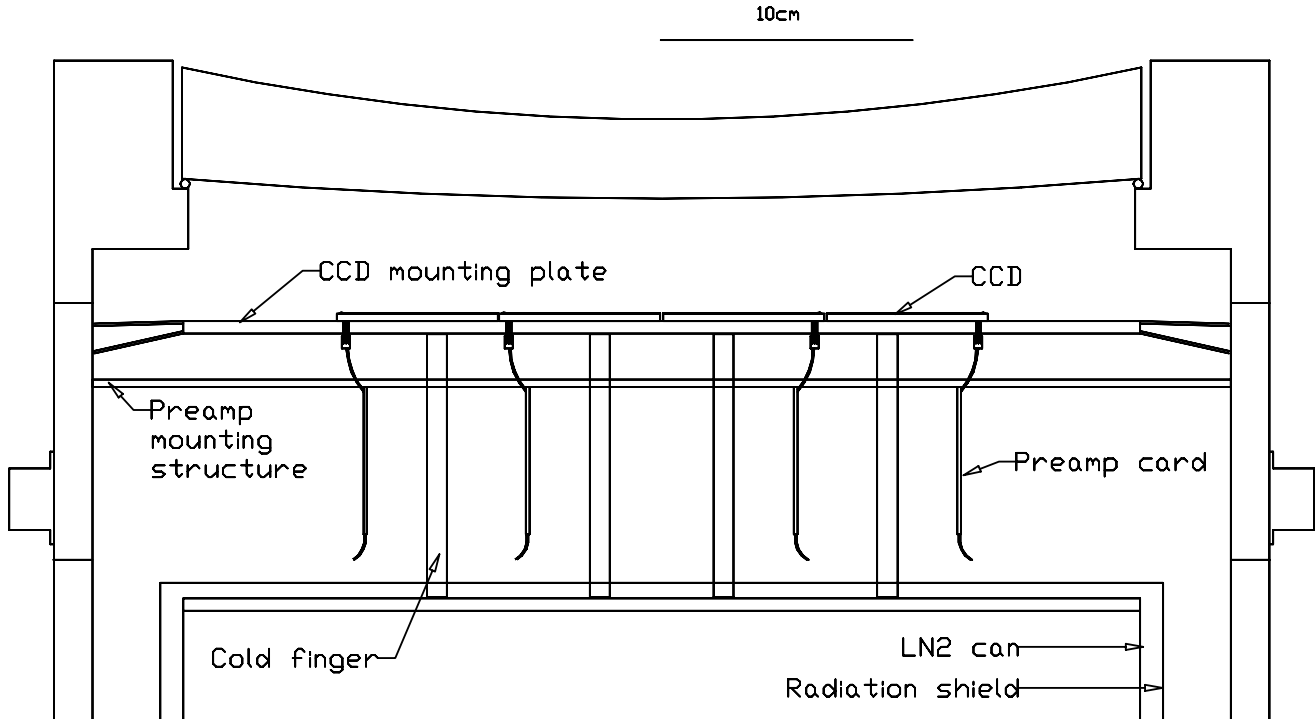

Fig. 5.—: Conceptual design of CCD dewar.

header is attached to the end of the Invar mounting plate with the electrical connections extending downwards. Wirebonds connect the CCD to the header.

2.3 Electronics and Control System

The control system is designed around the San Diego State University CCD control electronics.³ We will use four sets of the control electronics, each one capable of reading from 16 CCD amplifiers. The clock signals from the four controllers will be synchronized to minimize noise from crosstalk. The controllers will be capable of reading out each CCD at a rate of 5 microsec per pixel or the whole mosaic in under 30 seconds. At this readout rate we may not achieve the lowest possible readout noise. However, for broadband images of just a few minutes long, the sky background noise will dominate over the read noise, and so the total noise will not be compromised by reading quickly. Each of the four controllers sends its data via a fiber-optic link to the instrument control computer. The computer will be a server class machine with four SBUS cards (to interface to the controllers), 100 GB of disk space, and digital linear tape drives. The data will be written to disk in real time and eventually archived onto tape, each of which has a capacity of 40GB.

2.4 Dewar

A conceptual drawing of the cryogenic dewar is shown in Figure 5. It will consist of three detachable sections containing the optics, CCDs, and, cryogenics assemblies. The top section contains only the field-flattening window. The middle section contains the CCD packages all bolted to a cold Invar plate. The pins of the CCD go through a slot in the plate, where a constantan wire bundle leads to a preamp board hanging below the CCD. Another

connector on the preamp board provides the connection to the outside of the dewar. This modular approach should make it relatively easy to replace CCDs or preamp cards. The bottom section of the dewar contains the liquid nitrogen vessel, a radiation shield, and a set of spring-loaded cold fingers that extend upwards to contact the CCD cold plate. The anticipated nitrogen consumption is 50 liters per day.

2.5 Filters

The filters must be 26cm square. Broadband UBVRI filters can be made of either colored glass or interference coatings, or a hybrid. For narrow-band imaging, interference filters are the only option. Interference filters with 100Å width can be manufactured in this size. Narrower filters may be possible, though the fast focal ratio will cause an intrinsic FWHM of approximately 10Å. The optics also cause a 1Å center wavelength shift to the blue from the center to the edge of the field.

2.6 Guiding

Autoguiding will be done with two additional 2kx4k (possibly unthinned or otherwise not quite perfect) CCDs in the focal plane. These devices will be operated in frame-transfer mode, giving an active area of 2kx2k pixels. Stars can be located by reading out the full array. Subsequently, a small area around the guide star will be read out at 1Hz for guiding. Both the tracking and rotation can be controlled by using the pair of guiding chips. The guider chips will use the CCD controller electronics that are normally used by Hectospec or other MMT CCD instruments.

Each position in the main filter wheel will have separate filters for the guide CCDs. For guiding with maximum throughput, clear glass can be used, however for minimizing errors due to differential refraction, it may be desirable to guide at the wavelength of observation. With no filter, guide stars can be as faint as R=20.5. At the galactic pole the density of stars is still high enough to give more than a 99.8% chance of finding a guide star in each chip at any location.

3 REFERENCES

- [1] Fabricant, D., Hertz E., and Szentgyorgyi A., "The Hectospec: a 300 optical fiber spectrograph for the converted MMT," SPIE, 2198, 251-263, March 1994
- [2] Fata, R., and Fabricant D., "Design of a Cell for the Wide-Field Corrector for the Converted MMT," SPIE, 1998, 32-38, July 1993
- [3] Leach, R. W., "Design of a CCD Controller Optimized for Mosaics," Pub. Astr. Soc. Pacific, 100, 1287-1295, 1988