



Kepler: A Search for Terrestrial Planets

SCP to SOC
Interface Control Document

KSOC-21112-002

3/29/2007

**NASA Ames Research Center
Moffett Field, CA. 94035**

**Warning! This printed copy may not be the latest released version.
It is the User's responsibility to verify this is the latest released version as identified in the
Tracked Documents List before use.**

Approved by: _____ Date _____
David W. Latham, SCP Lead, SAO

Approved by: _____ Date _____
David Monet, SCP Team, USNO

Approved by: _____ Date _____
Janice Voss, Science Director

Approved by: _____ Date _____
Rick Thompson, Ground Segment Systems Engineer

Approved by: _____ Date _____
Mike Hines, Deputy Project Manager for the Ground Segment

Approved by: _____ Date _____
Dave Koch, Deputy Principal Investigator

Prepared by: _____ Date _____
Chris Middour, SOC Systems Engineer

Document Control

Ownership

This document is part of the Kepler Project Documentation that is controlled by the Kepler Project Office, NASA/Ames Research Center, Moffett Field, California.

Control Level

This document will be controlled under KPO @ Ames Configuration Management system. Changes to this document **shall** be controlled.

Physical Location

The physical location of this document will be in the KPO @ Ames Data Center.

Reference Documents

Distribution Requests

To be placed on the distribution list for additional revisions of this document, please address your request to the Preparer:

Chris Middour
MS 244-30
Moffett Field, CA 94035-1000
cmiddour@mail.arc.nasa.gov

DOCUMENT CHANGE LOG

CHANGE NUMBER	CHANGE DATE	PAGES AFFECTED	CHANGES/ NOTES
001	06/24/03	All	First Draft
002	08/12/03	All	Updated Terminology
003	09/04/03	All	Second Draft
004	10/08/03	All	Updates to 2 nd draft
005	03/29/04	All	Updates from 3/26/2004 meeting with Dave Latham, Dave Monet, Tim Brown, Jeff Shapiro, and Jeff Crilly
006	05/12/04	ALL	Updates from the SCP team
007	05/18/04	ALL	Updates from SOC review, add issues section, put in GS ICD template format.
008	5/28/04	ALL	Updates from SOC/SCP review.
009	3/11/05	All	Updates from review and new DB format provided by SCP.
010	4/6/05	Appendix A	Based on 3/28/05 release of KIC
011	4/19/05	4.2.3-4.2.7	Input from Tim Brown
012	4/21/05	Appendix A	Corrected v4 KIC Schema
013	2/23/06	Appendix A	Changed "KICID" column name to "KEPLER_ID"
014	7/26/2006	4.2.1.10	Added a 4 th (and final) release to be sent 12/31/2007, reflecting the launch date moving out.
015	12/06/2006	Appendix A	Add manifest with checksums.
016	3/29/2007	Appendix A	Updated for new schema for catalog due to arrive December 2007.

Table of Contents

Table of Contents	5
List of Figures.....	6
Tables.....	6
Appendices.....	6
1. INTRODUCTION.....	7
1.1 Purpose and Scope	7
1.2 Intended Audience.....	7
1.3 Document Overview	8
2. DOCUMENTS	9
2.1 Compliance Documents.....	9
2.2 Reference Documents	9
3. INTERFACE DESIGN	10
3.1 Interface Identification and diagrams.....	10
3.2 Context.....	10
3.3 Interface Definitions	11
4. Data Products.....	12
4.1 "SO-SCP Kepler FOV"	12
4.1.1 General.....	12
4.2 "SCP-SOC Kepler Input Catalog"	13
4.2.1 General.....	13
4.2.2 Kepler Input Catalog Data Format.....	14
4.2.3 Characterization of the errors for all observed and derived quantities.....	15
4.2.4 Characterization of data completeness (Example: Areas in the Kepler FOV with no data)	16
4.2.5 Model used to estimate Stellar Radii.....	16
4.2.6 Model used to calculate Kepler Magnitude	16
4.2.7 Model used to calculate Reddening and Extinction.	16
4.3 Release History	17
4.4 KIC Schema.....	17
4.4.1 Table Notes:	19
4.4.2 ALTSOURCE values:	19
4.4.3 CQ Values:	19
4.4.4 PQ Values	20

4.4.5 AQ Values 20
4.5 Schema for CATKEY Database 20
4.6 Notes..... 20
4.7 Schema for SCPKEY Database 21
4.7.1 Notes: 21

List of Figures

Figure 1. Kepler Ground Segment Elements and Interfaces 7
Figure 2. Interface data flow context diagram..... 10

Tables

Table 1 Interface Identification 11

Appendices

Appendix A. "Kepler Input Catalog" 17

1. INTRODUCTION

1.1 Purpose and Scope

This document defines the interface between the Stellar Classification Program (SCP) and the Kepler Science Operations Center (SOC). The SCP-SOC ICD defines the format and specifications of the Kepler Input Catalog being developed by the SCP for delivery to the SOC, in addition to any related data flows between the SOC and the SCP.

The SO provides a detailed description of the Kepler Field of View (FOV) to the SCP. The SCP delivers the Kepler Input Catalog (KIC) to the SOC. The SOC then uses this catalog to determine the actual Kepler target list.

The Kepler Input Catalog is a description of the sky in the Kepler FOV. It will give positions, proper motions, apparent magnitudes (in several different passbands), and derived astrophysical parameters for stars in this region.

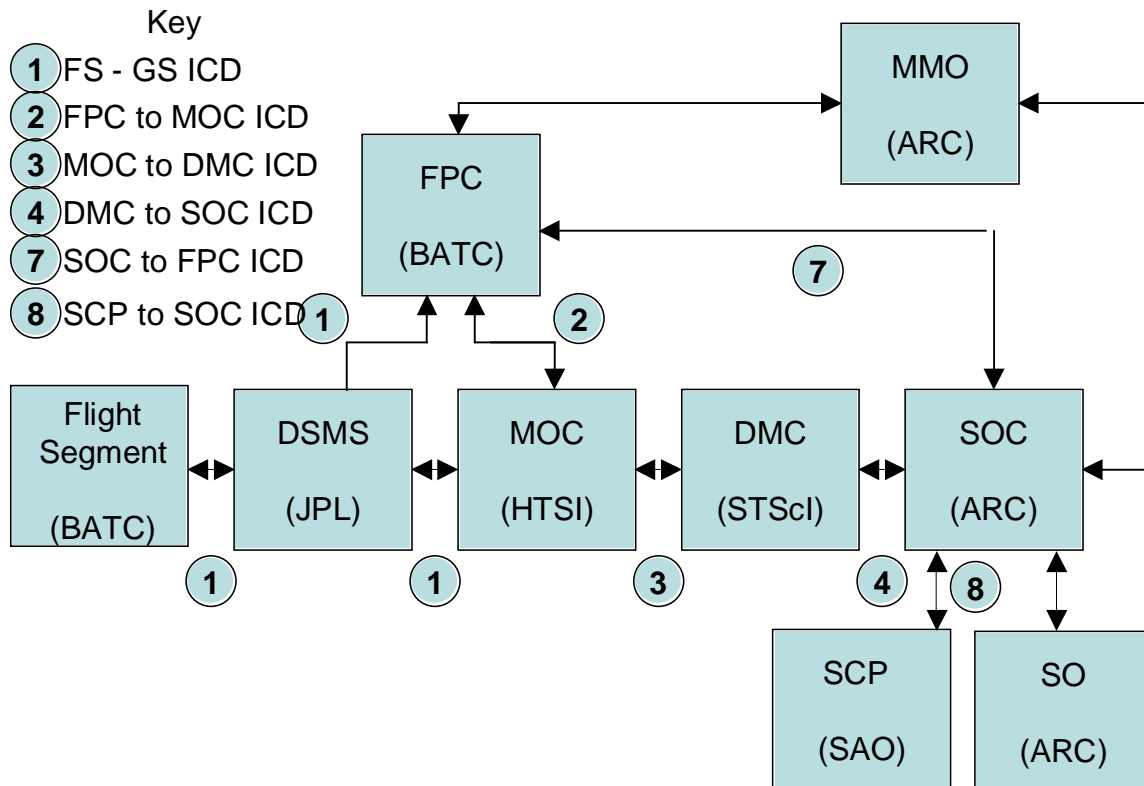

Figure 1. Kepler Ground Segment Elements and Interfaces

1.2 Intended Audience

The intended audiences of this document are:

- The SCP team which will be developing the KIC,

- The SOC team which will be integrating the KIC,
- The SO team which will be using the KIC via the SOC to select the Kepler Target List.
- Scientific users of Kepler who need information about stars in the Kepler FOV.

1.3 Document Overview

This document is organized as follows:

- Section 2 covers external documents relevant to the ICD, including reference to the catalogs that are used to create the KIC.
- Section 3 provides an overview of the SOC-SCP interface, identifying the flows between the SOC and SCP.
- Section 4 details the specific data items flowing between the SOC and the SCP. This identifies the Kepler FOV specification (from SOC to SCP) and the KIC (from SCP to SOC).
- Appendix A describes the actual format of the KIC.
- Appendix B describes the data flow between the SOC and the SCP.

2. DOCUMENTS

2.1 Compliance Documents

The following documents take precedence over this document:

- Kepler Ground Segment Requirements Document (GSRD) – KGSS-14004
- Kepler Science Operations Center (SOC) Requirements – KSOC-21003
- Data Release Policy
- Kepler Security Policy

2.2 Reference Documents

The following catalogs are referenced by the Kepler Input Catalog. The URLs are correct as of Feb 2005.

Hipparcos catalog

<http://cdsweb.u-strasbg.fr/cats/I.htx> I/239

Tycho-2 catalog

<http://cdsweb.u-strasbg.fr/cats/I.htx> I/239

UCAC-2 catalog with extensions

<http://cdsweb.u-strasbg.fr/cats/I.htx> I/289

NED database

<http://nedwww.ipac.caltech.edu>

2MASS PSC and XSC catalogs

<http://cdsweb.u-strasbg.fr/cats/II.htx> II/246

FIRST catalog

<http://cdsweb.u-strasbg.fr/cats/VIII.htx> VIII/71

NVSS catalog

<http://cdsweb.u-strasbg.fr/cats/VIII.htx> VIII/65

GCVS (General Catalog of Variable Stars)

<http://cdsweb.u-strasbg.fr/cats/II.htx> II/250

USNO YB7 catalog

(No URL available; contact D. Monet)

USNO USNO-B1.0 catalog

<http://cdsweb.u-strasbg.fr/cats/I.htx> I/284

3. INTERFACE DESIGN

3.1 Interface Identification and diagrams

3.2 Context

The SOC will provide the SCP with a detailed specification of the Kepler Field of View (FOV), including the J2000 Right Ascension and Declination of the corners of the active areas of all the CCDs, accurate to nominally 20 arc seconds.

The SCP will deliver the Kepler Input Catalog (KIC) to the SOC.

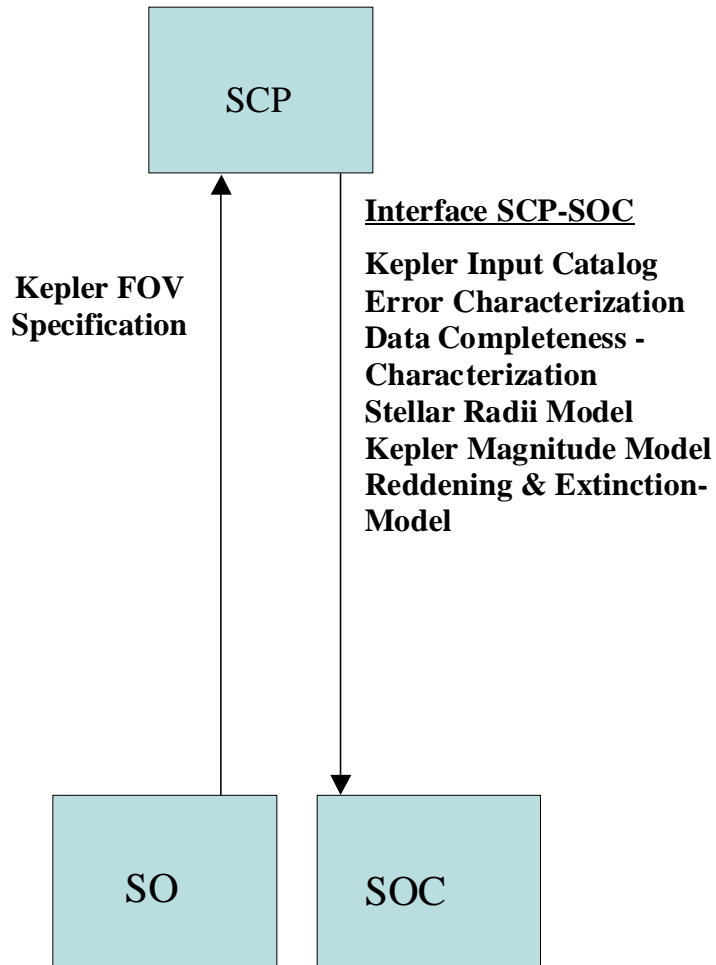

Figure 2. Interface data flow context diagram

3.3 Interface Definitions

Table 1 Interface Identification

Interface Id	Interface Title	Interface Description	Transport Method
SO.1.SCP	Kepler FOV	The SO will provide the SCP with the detailed specification of the Kepler FOV.	Email
SCP.1.SOC	Kepler Input Catalog	The Kepler Input Catalog being developed by the SCP for delivery to the SOC.	Physical Media US Postal Mail
SCP.2.SOC	Error Characterization	Characterization of the errors for all observed and derived quantities	Email
SCP.3.SOC	Data Completeness Characterization	Characterization of data completeness. (Example: Areas in the Kepler FOV with no data)	Email
SCP.4.SOC	Stellar Radii Model	Model used to estimate Stellar Radii	Email
SCP.5.SOC	Kepler Magnitude Model	Model used to calculate Kepler Magnitude	Email
SCP.6.SOC	Reddening & Extinction Model	Model used to calculate Reddening & Extinction	Email

4. Data Products

4.1 “SO-SCP Kepler FOV”

4.1.1 General

The SO will provide the SCP with a detailed specification of the Kepler FOV, including the Kepler passband and CCD characterization such as Q.E.

4.1.1.1 Purpose

The SCP must know the location of the FOV to determine which stars will be included in the KIC, and the characteristics of the photometer, which are inputs to the Kepler magnitude model.

4.1.1.2 Composition

The SO will deliver the following products to the SCP:

- Center of the Kepler FOV.
- J2000 Right Ascension and Declination of the corners of the active areas of all the CCDs, accurate to nominally 20 arc seconds, or better. (This effectively will specify where the gaps lie. The position of the Fine Guidance Sensors (FGS) is not required.

4.1.1.3 Source

SO

4.1.1.4 Recipient

SCP

4.1.1.5 Interface type

Kepler Design Note document.

4.1.1.6 Priority

N/A

4.1.1.7 Naming Convention

N/A

4.1.1.8 Conditions for Transfer

This is a “manual” transfer. As the Kepler FOV specification is finalized or updated by the mission, the SOC will inform the SCP of the new FOV.

4.1.1.9 Transport Mechanism

E-Mail

4.1.1.10 Synchronization and flow control

The SOC initiates the transfer of the Kepler FOV specification to the SCP when the Kepler FOV is made available and approved by the Mission.

4.1.1.11 Security

N/A

4.1.1.12 Error Handling and Recovery

In the event the SCP does not receive the Kepler FOV from the SOC, the SCP will inform the SOC. The SOC and the SCP will resolve the problem with the transfer, correct the problem, and the SOC will resend the Kepler FOV specification to the SCP.

4.2 “SCP-SOC Kepler Input Catalog”

4.2.1 General

The driving requirements for the KIC as specified in the GSRD are to provide for each object in the catalog the following [TBR]:

- Position
- Brightness in the Kepler passband as defined by the Kepler magnitude model.
- Size (Radius)

4.2.1.1 Purpose

The KIC will provide the primary (but not the only) input used to create the Kepler Target List.

4.2.1.2 Composition

The SCP will deliver the following products to the SOC:

- Kepler Input Catalog in a format described in Appendix A.
- Characterization of the errors for all observed and derived quantities.
- Characterization of data completeness. (Example: Areas in the Kepler FOV with no data)
- Model used to estimate Stellar Radii.
- Model used to calculate Kepler Magnitude.

4.2.1.3 Source

SCP

4.2.1.4 Recipient

SOC

4.2.1.5 Interface type

CD or DVD via US Postal Mail or Courier

4.2.1.6 Priority

N/A

4.2.1.7 Naming Convention

Each file containing a portion of the KIC is named by the declination included in the file. For example, if the file contains objects in declination +44 degrees, then the file will be named “d0440.mrg”.

4.2.1.8 Conditions for Transfer

The KIC will be delivered according the schedule defined by this ICD. See Section 4.2.1.10.

4.2.1.9 Transport Mechanism

Delivery medium for the KIC is expected to be DVD, compressed if necessary.

4.2.1.10 Synchronization and flow control

The Kepler Input Catalog should be delivered in stages, with preliminary releases as they are completed, and a final release, defined by the schedule below.

The Kepler Input Catalog will be delivered in staged releases as follows:

Release #	Date	Status
0	May. 2004	Prototype
0.5	06/30/2004	Prototype with Derived Quantities
1	12/31/2004	Preliminary
2	12/31/2005	Updated
3	12/31/2006	Updated
4	12/31/07	Final

The SOC will review each release of the Kepler Input Catalog and provide feedback to the SCP within 60 days of release. There may also be unofficial interim releases of the KIC, between the dates specified in the table above. These interim releases will be used to test possible format changes before an official release, or to provide access to the latest observations in a timely manner. It is assumed that there may be several interim releases; however the SCP is under no obligation to provide them.

4.2.1.11 Security

The SOC shall verify that the KIC sent by the SCP to the SOC has not been tampered with or altered.

Access to the KIC shall comply with the Kepler Data Release Policy.

4.2.1.12 Error Handling and Recovery

In the event that the SOC does not receive the KIC, the SOC will inform the SCP. Both elements will then resolve the problem, possibly requiring the SCP to resend the KIC using another mechanism.

4.2.2 Kepler Input Catalog Data Format

4.2.2.1 Composition

It is estimated that the KIC will contain approximately 15 million stellar and non-stellar objects across the Kepler FOV. The catalog will cover the entire FOV with at least 5 arc minute margin around the outside of the FOV to accommodate small changes to the FOV after the catalog is created.

The format of the KIC will be flat ASCII. The separator character for each column will be the "vertical bar" character, "|", Hexadecimal 7C. Header data included in the file will contain a description of the file including version information, and a description of the columns.

The size of the KIC is expected to be approximately 5 Gigabytes.

The Kepler Input Catalog will contain the following parameters:

- Object Identifier
- *Observable Quantities*
- Position

- Proper Motion
- Apparent magnitude in the following passbands:
- SDSS u, g, r, i, z; SAO D51, G_{red}; 2MASS J, H, K, Kepler passband
- 2MASS ID, YB6 ID, Alt ID, Alt Cat ID
- Galaxy
- Blend
- Variability

Derived Quantities

- Effective Temperature
- Surface Gravity
- Metallicity
- Reddening
- Extinction
- Radius

The exact format of the catalog is described in Appendix A.

The performance requirements for the Kepler Input Catalog are RMS values as follows:

- Positions shall be accurate to 200 mas.
- Proper motions shall be determined to 20 mas/yr.
- Photometry shall be accurate to 0.02 magnitude RMS, with the following exceptions:
 - u band will be 0.04 magnitude.
 - z band will be 0.03 magnitude.
- Effective temperature shall be accurate to 200K .
- Log(surface gravity) shall be accurate to 0.5 dex .
- Metallicity shall be accurate to 0.5 dex .
- Reddening shall be accurate to 0.1 magnitude.
- All 2MASS stars brighter than K = 14.0 shall be included.

Once the final release of the Kepler Input Catalog is delivered to the SOC, no further changes to the catalog will be required.

4.2.3 Characterization of the errors for all observed and derived quantities

Errors will be described in a text document, available in MS Word and PDF formats. The document will describe formulas by which errors for all quantities may be estimated based on their observed magnitudes. Errors in the magnitude estimates will also be described in an ASCII table giving typical magnitude errors vs. magnitude individually for each filter, on a grid of magnitudes between 9 and 17, in steps of 0.5. Errors in derived quantities are expected to have more complicated dependences that are not amenable to representation in tables.

4.2.4 Characterization of data completeness (Example: Areas in the Kepler FOV with no data)

Data completeness will be described in a text document, available in MS Word and PDF formats. This document will contain various statistical measures of the data completeness, including the area in the Kepler FOV with no data, the area in the Kepler FOV with incomplete data (i.e., with no stars in one or more of the filters {g,r,i,z,D51,J,H,K}), the number of stars that are detected in all of the above filters, the number of stars detected in all but one of the above filters for each possible choice of the missing filter, and other indices. The text will be augmented by images available in tiff and in FITS formats, showing the \log_{10} of the number of stars in each square 0.05 degree on a side (corrected for $\cos(\text{declination})$), in each of the above filters.

4.2.5 Model used to estimate Stellar Radii

This model will be described in a text document, available in MS Word and PDF formats. It will include a description of the strategy employed, it will describe the methods used to validate the results, and it will lay out the formulas that are implemented in the radius estimation programs. The IDL code for key routines will be provided in flat ASCII text files.

4.2.6 Model used to calculate Kepler Magnitude

This model will be described in a text document, available in MS Word and PDF formats. It will include a description of the strategy employed, it will describe the methods used to validate the results, and it will lay out the formulas that are implemented in the Kepler magnitude estimation programs. The IDL code for key routines will be provided in flat ASCII text files.

4.2.7 Model used to calculate Reddening and Extinction.

This model will be described in a text document, available in MS Word and PDF formats. It will include a description of the strategy employed, it will describe the methods used to validate the results, and it will lay out the formulas that are implemented in the reddening and extinction estimation programs. The IDL code for key routines will be provided in flat ASCII text files.

Appendix A. “Kepler Input Catalog”

The protocol for the Kepler Input Catalog will be a format agreed upon by both the SOC and SCP. The format for the KIC is as follows:

1. Configuration control information including version and date is to be provided.
2. The KIC is divided into approximately 200 flat ASCII files by 0.1-degree declination bands.
3. Each file is sorted in RA.
4. Each line in a file contains all the data for one entry.
5. Each data field is separated by | (vertical bar). There is no bar before the first field and after the last field.
6. A field that has no value, that is, a “null” value, will be blank.
7. Each line is terminated by <newline>.
8. Checksums for each file are to be provided in a file called *Manifest* in the same directory as the data files. The type of checksum is MD5. The command that is used to create this file is this:

```
md5sum *.mrg > Manifest
```

4.3 Release History

Version	Approx Date	Comments
7	15 Dec 2006	Rename YBID to SCPID and revised content. New schema, content, etc., for SCPKEY database as per SCP Team spectroscopy, etc.
6	22 Feb 2006	Old KICID is now KEPLER_ID. No effect on content.
6	6 Jan 2006	Fixed KEPMAG for non-SCP stars
5	29 Dec 2005	Called KIC05 as per SOC/SCP ICD. Same schema as (4). Lots more SCP data.
4	28 Mar 2005	Recalibration of photographic magnitudes.
3	17 Feb 2005	Added colors, fixed bugs, added documentation, should be version for Team in May 05
2	1 Feb 2005	Astronomer units instead of integers. Added PARLX, GLONG, GLAT fields.
1	05 Jan 2005	Fixed SPD/DEC error
0	27 Dec 2004	Dec 31 2004 release as per Requirements Document

4.4 KIC Schema

Column	DB Name	Type	Units	Format, comments, etc.
1	RA	double	hours	Right Ascension (HH.HHHHHHHH)
2	DEC	double	degrees	Declination (sDD.DDDDDD)
3	PMRA	float	arcsec/year	RA proper motion(sMM.MMMM)

4	PMDEC	float	arcsec/year	Dec proper motion (sMM.MMMM)
5	UMAG	float	magnitudes	u-band magnitude (MM.MMM)
6	GMAG	float	magnitudes	g-band magnitude (MM.MMM)
7	RMAG	float	magnitudes	r-band magnitude (MM.MMM)
8	IMAG	float	magnitudes	i-band magnitude (MM.MMM)
9	ZMAG	float	magnitudes	z-band magnitude (MM.MMM)
10	GREDMAG	float	magnitudes	GRed band magnitude (MM.MMM)
11	D51MAG	float	magnitudes	D51 band magnitude (MM.MMM)
12	JMAG	float	magnitudes	2MASS J-band magnitude (MM.MMM)
13	HMAG	float	magnitudes	2MASS H-band magnitude (MM.MMM)
14	KMAG	float	magnitudes	2MASS K-band magnitude (MM.MMM)
15	KEPMAG	float	magnitudes	Kepler-band magnitude (MM.MMM)
16	KEPLER_ID	int	(none)	Unique KIC catalog ID
17	TMID	int	(none)	Unique 2MASS catalog ID
18	SCPID	int	(none)	Unique SCP processing ID
19	ALTID	int	(none)	ID in other catalog (see 20)
20	ALTSOURCE	int	(none)	Source catalog for ALTID (see 19)
21	GALAXY	int	(none)	Star/galaxy indicator
22	BLEND	int	(none)	Isolated/blended indicator
23	VARIABLE	int	(none)	Constant/variable indicator
24	TEFF	int	degrees	K Effective temperature (TTTTT)
25	LOGG	float	cm/sec**2	LOG10 surface gravity (sL.LLL)
26	FEH	float	solar	LOG10 Fe/H metallicity (sL.LLL)
27	EBMINUSV	float	magnitudes	E(B-V) reddening (sM.MMM)
28	AV	float	magnitudes	A_V extinction (M.MMM)
29	RADIUS	float	solar	Radius (RRR.RRR)
30	CQ	string	(none)	Source of data - see Notes
31	PQ	int	(none)	Photometry quality indicator
32	AQ	int	(none)	Astrophysics quality indicator
33	CATKEY	int	(none)	Unique integer key to CATALOG

				DB
34	SCPKEY	int	(none)	Unique integer key to SCP DB
35	PARALLAX	float	arcsec	Parallax (sP.PPPP)
36	GLON	float	degrees	Galactic longitude (DDD.DDDDDD)
37	GLAT	float	degrees	Galactic latitude (sDD.DDDDDD)
38	PMTOTAL	float	arcsec/year	Total proper motion (MM.MMMM)
39	GRCOLOR	float	magnitudes	g-r color (sM.MMM)
40	JKCOLOR	float	magnitudes	J-K color (sM.MMM)
41	GKCOLOR	float	magnitudes	g-K color (sM.MMM)

4.4.1 Table Notes:

The TYPE field shows the suggested minimum precision for storage of the value. The string in the COMMENTS field shows the format of the entry in the ASCII version of the database files.

4.4.2 ALTSOURCE values:

Value	Comments
0	ALTID contains NULL
1	ALTID contains Hipparcos catalog ID
2	ALTID contains Tycho2 catalog ID
3	ALTID contains UCAC2 catalog ID
4	ALTID contains General Catalog of Variable Stars ID
11	ALTID contains NED catalog ID
12	ALTID contains Extended 2MASS Catalog ID
13	ALTID contains FIRST catalog ID
14	ALTID contains NVSS catalog ID

4.4.3 CQ Values:

ASCII character string indicating the source of the calibrated data.

Value	Meaning
NOCAL	No calibration to optical magnitudes possible. Used for entries from non-optical catalogs
2MASS	Objects found only in 2MASS catalog with no optical counterpart
UNCAL	Lack of SCP photometric calibrators on photographic plate prevents calibration. Values are raw photographic magnitudes in closest band.
PHOTO	Photographic magnitudes calibrated to Kepler bands.
SCP	CCD magnitudes from SCP

4.4.4 PQ Values

Placeholder for SCP values that have yet to be determined. Current version is value between 0-11 which is the count of non-NULL entries in UMAG, GMAG, RMAG, IMAG, ZMAG, GREDMAG, D51MAG, JMAG, HMAG, KMAG, and KEPMAG.

4.4.5 AQ Values

Placeholder for SCP values that have yet to be determined. Current version is value between 0-6 which is the count of non-NULL entries in TEFF, LOGG, FEH, AV, EBMINUSV, RADIUS.

4.5 Schema for CATKEY Database

Column	DB Name	Type	Units	Format, comments, etc.
1	CATKEY	int	(none)	Unique integer key to CATALOG DB
2	CATFLAG	int	(none)	Bit flag from catalog merge
3	TYCHOID	int	(none)	Original ID in Tycho-2 catalog
4	UCACID	int	(none)	Original ID in UCAC catalog
5	GCVSID	int	(none)	Original ID in GCVS catalog
6	SOURCE	character	(none)	STAR, XTM, NED, NVSS, FIRST
7	SOURCEID	int	(none)	ID in original catalog
8	FLUX1	int	(variable)	First flux in original catalog
9	FLUX2	int	(variable)	Second flux in original catalog
10	RAEPOCH	float	year	Epoch of RA coordinate
11	DECEPOCH	float	year	Epoch of Dec coordinate
12	JMAG	float	mag	2MASS J magnitude
13	HMAG	float	mag	2MASS H magnitude
14	KMAG	float	mag	2MASS K magnitude

4.6 Notes

- 1) If the object is a star with one or more cross-identifications in the UCAC, Tycho2, or GCVS catalogs, SOURCE is set to STAR, and all cross-identifications are listed.
- 2) If the object comes from a non-optical or other special catalog, SOURCE is set to the name of the catalog (XTM, NED, NVSS, FIRST) and the FLUX1 and FLUX2 are set to the fluxes listed in those catalog.
- 3) All entries have non-NULL values for CATKEY, CATFLAG, and SOURCE. For STARS, there will be at least one non-NULL value in TYCHOID, UCACID, and GCVSID. For galaxies and other peculiar objects, there should be non-NULL values in SOURCEID, FLUX1, FLUX2 (depending on catalog), RAEPOCH and DECEPOCH. XTM sources will have non-NULL values in JMAG, HMAG, and KMAG.

4.7 Schema for SCPKEY Database

Column	DB Name	Type	Units	Format, comments, etc.
1	SCPKEY	int	(none)	Same as KIC column 34
2	SCP_FIBER_RA	double	hours	Right Ascension (HH.HHHHHHH)
3	SCP_FIBER_DEC	double	degrees	Declination (sDD.DDDDDD)
4	SCP_TEFF	int	degrees	Effective temperature (TTTTT)
5	SCP_TEFF_ERR	int	degrees	Error in SCP_TEFF (TTTTT)
6	SCP_LOGG	float	cm/sec**2	LOG10 surface gravity (sL.LLL)
7	SCP_LOGG_ERR	float	cm/sec**2	Error in SCP_LOGG (sL.LLL)
8	SCP_FEH	float	solar	LOG10 Fe/H metallicity (sL.LLL)
9	SCP_FEH_ERR	float	solar	Error in SCP_FEH (sL.LLL)
10	SCP_VSINI	float	km/sec	Rot. $V \cdot \sin(\text{incl})$ (kkkk.kkk)
11	SCP_VSINI_ERR	float	km/sec	Error in SCP_VSINI (kkkk.kkk)
12	SCP_RV	float	km/sec	Radial Velocity (skkkk.kkk)
13	SCP_RV_ERR	float	km/sec	Error in SC_RV (kkkk.kkk)
14	SCP_CCPH	float	(none)	Cross correlation peak (p.ppp)

4.7.1 Notes:

- 1) SCPKEY database contains values determined by spectroscopy as differing from photometry.
- 2) Values for any or all columns in SCPKEY database need not agree with values listed in KIC. In particular, the SCP_FIBER_RA and SCP_FIBER_DEC refer to the focal plane position of the spectrograph fibers, and are not the catalog positions for the stars.
- 3) Extended discussion and documentation for the values in the SCPKEY database are provided in the written summaries of the SCP, and are not repeated here.