

Summary of Meetings about PISCO, Pasadena April 2006

Antony A. Stark

Smithsonian Astrophysical Observatory, MS12, Cambridge MA 02138

1st Draft 17 April 2006

aas@cfa.harvard.edu

This memo summarizes discussions at meetings that took place on 6 and 7 April 2006 at the Carnegie Observatories building in Pasadena. Immediately preceding the meeting for PISCO was a presentation by Robert Simcoe of MIT, who is proposing an infrared spectrometer named FIRE for a folded f/11 port. Meeting with me on 6 April where Alan Uomoto, Magellan Technical Manager, Frank Perez, Magellan Project Supervisor, and Gabriel Martin, Magellan Instrument Specialist. On 7 April was the first day of the Magellan Science Advisory Committee, and I gave a 30-minute presentation to the committee about PISCO.

Here are discussion items, in approximately the order they were raised.

1. Magellan uses primarily English-unit screws. There are few metric spares on site.
2. The flange on the “Small Guider Housing” on the f/11 port should be taken to be concentric with and perpendicular to the beam from the telescope for purposes of internal alignment of the instrument. There is provision for a removable dowel bushing on the flange, that can take either a “diamond” or “dowel pin” fitting. This can be used to center the instrument on the flange, but is rarely used. More commonly used is the 0.350 inch deep 36 inch diameter cylindrical detent in the Small Guider Housing flange. This cylinder is concentric with the beam and can be engaged by a boss on the instrument flange. It is important that boss and detent not engage around the full circumference, but only over a limited contact area; otherwise there is too much friction to easily engage and disengage.
3. The Small Guider Housing is full of the machinery for two star guiders, so no cables can be run through the inside of it. All cables and hoses for the instrument should be routed through a wrap, then across the outside of the Small Guider Housing. This is done badly in MegaCam. Consult Frank Perez about the design.
4. All hoses and cables that go through the wrap should be easily and cleanly disconnectable at the instrument, preferable in a single location near the mounting flange.
5. The flange where the folded port instruments attach to the body of the telescope is undersized. There is, therefore, a stringent limit to the allowed moment applied to the

Small Guider Housing flange by the instrument: 1.1×10^5 in lbs. See figure 1. There is, however, plenty of room for a long instrument.

6. Getting a vacuum pump or leak checker up to the folded ports is a perennial observatory problem that needs to be solved, perhaps with a dedicated pump on a lift.
7. Four pair of Helium hoses for the four Cryotigers on PISCO is a lot to run through the wrap. Can more than one cold head be run from one pair of Helium hoses?
8. A 10% glycol solution at ambient temperature is circulated throughout the observatory for removing heat. Instruments can release no more than 50 Watts to the air in the dome. The glycol lines are present in the Small Guider Housing. The glycol used is Dow Therm SR-1.
9. Use of Conflat fittings for flange joints on instrument vacuum vessels is encouraged.
10. The Magellan observatory should provide a standard for on-site data storage—some kind of cross-mountable, pooled data storage system with removable disks.
11. IRIG B timing signals are circulated at the observatory. Not known: is it TTL-level, or analog modulated?
12. There is a link to the Telescope Control Software (TCS) that is accessible to instruments. Instruments can control the telescope for small motions. Instruments can request large slews, but these must be OKed by the telescope operator.
13. Magellan software is generally written in C and Linux-based. Useful for this purpose is the GTK+ library. It is in the public domain and written in C. SpeXtool. Reference: Cushing et al. 2005. Contact person: Matt Nelson.
14. The computer network at Magellan is being upgraded to 1 GBs. Jim Hughes is the network person, but requests should go through Frank Perez.
15. There are three reviews that each instrument must pass: a Design Review, an informal Pre-ship readiness review, and the formal director’s pre-ship review. This last should be just a formality. PI instruments like PISCO will be subjected to an only slightly less rigorous set of requirements than Facility Instruments.
16. Needed for Design Review: a) essentially complete mechanical design, with all details; b) give special emphasis to optical mounts and alignment plan; c) minimize alignment screws: where possible, optical parts should be attached to accurately-machined mounts, pinned, and shimmed if necessary; d) understand all optical tolerances; e)

understand thermal issues with alignment; f) understand all scattered and reflected light issues, all baffles must be designed, although ZEMAX defaults for this analysis are probably OK (Where will glints show up on supports?); g) a full FEA of the instrument for force variations with elevation and rotation.

17. Needed for Pre-Ship Review: a) Documentation for assembly and mounting of instrument, including all details; b) Documentation on CCDs, turn-on and turn-off procedures, power failure procedures; c) see attached copy of instruments policy.
18. Check out instrument shutters made by Mike Carr (<http://www.sciin.com>) which are commercially available.
19. A very good thing to do for stray light suppression is to put a baffle at in image of the tertiary. This will eliminate most of the stray light from the dome, etc.
20. Since the front surface of the dichroics are used, partly, as mirrors, care must be taken to make sure that they do not distort too much under varying gravity vector. The “rule of thumb” is that the thickness of a solid glass mirror should be $1/6^{\text{th}}$ of the diameter. Fused silica may be better in this respect than glass as a substrate for the dichroics. Also, PISCO is not diffraction-limited, so error analysis needs to be done.
21. Large slews with Magellan telescopes require 2 minutes of telescope settling time, because the figure of the primary must be re-adjusted. PISCO observations should be planned with many small slews that do not require this re-adjustment.

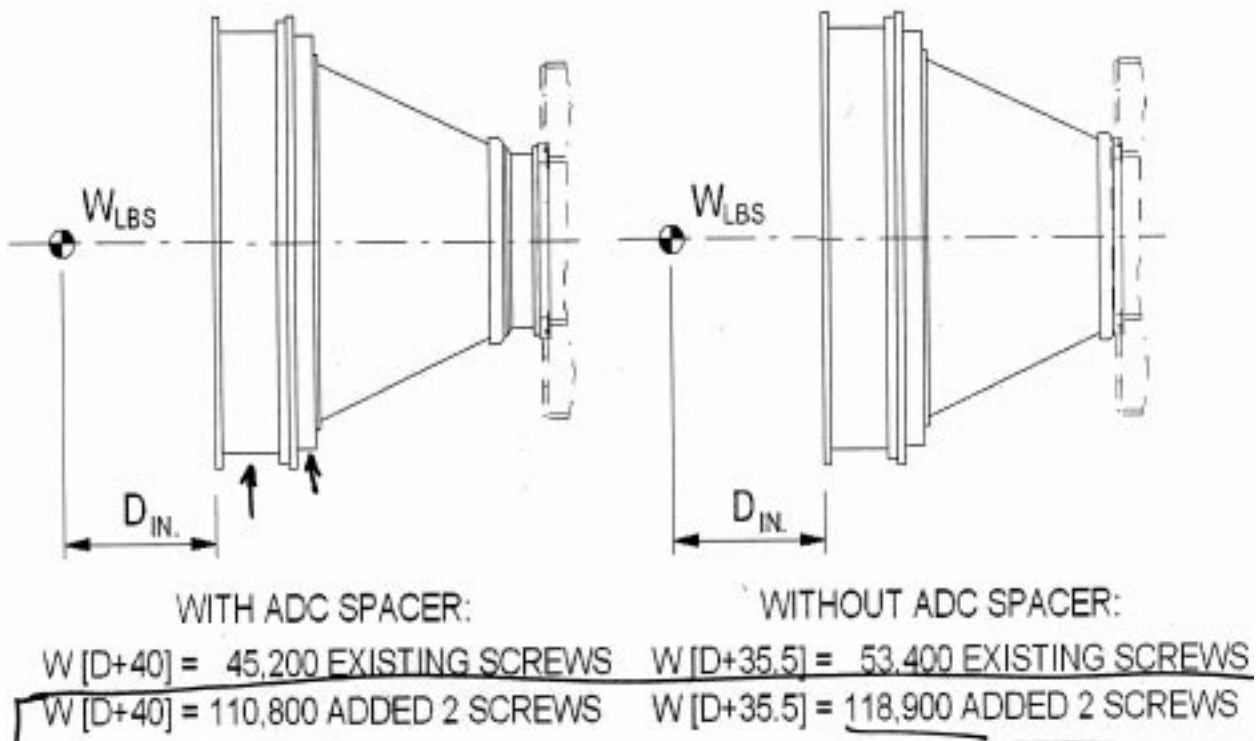

Fig. 1.— Allowable moment arm on the Magellan folded $f/11$ ports. The telescope is to the right, instrument to the left.

Magellan Facility Instruments Policy

September 25, 2001

Revised October 7, 2001

Revision E: April 15, 2002

Doc. No. 01PM004

1. Purpose

The purpose of this document is to define the procedures governing how facility instruments are proposed, approved, commissioned and accepted for the Magellan telescopes. Procedures for retiring facility instruments are also described.

Facility Instruments are defined in the Magellan Agreement as “those [instruments] that Consortium Members contribute in fulfillment of their obligations” under the agreement. More generally, they constitute the core set of science instruments for the Magellan 6.5-m telescopes. Facility Instruments are available to all users of the Magellan telescopes and are supported as continuing capabilities of the observatory. Because of the central role these instruments play in the scientific productivity of the observatory and the added demand they place on the observatory for support, the observatory staff, Magellan Science Advisory Committee (SAC) and Magellan Council will be more closely involved with Facility Instrument development and Facility Instrument operation than would normally be the case for non-Facility Instruments.

The other defined category of Magellan instrument, “User Instruments”, is any instrument not a Facility Instrument. User Instruments are not covered in this document.

No two Facility Instruments will follow the exact same development path. Some may start off as User Instruments and at some point be promoted to Facility status. Other instruments currently under development have already progressed beyond the initial proposal process and the procedures will have to be adjusted accordingly. The policy outlined below is meant as a guideline and may be modified as appropriate by the Council for individual cases.

2. Proposal Process

2.1. Proposal

The institution wishing to provide an instrument as a Facility instrument will prepare a written Proposal containing a description of scientific applications and the requirements, specifications, budget and schedule. The Proposal will be submitted to the SAC and an advance copy will be provided to the Observatory Staff.

Preliminary discussions within the SAC regarding the desirability of the proposed instrument or its specifications or its design may take place prior to submission of a proposal.

2.2. Observatory staff review

The Observatory Staff will review the Proposal and, working with the instrument group, (a) develop an estimate of the observatory resources necessary to put the instrument in service including possible modifications to the Magellan facility, (b) estimate the level of support required during routine operations and (c) reach an agreement with the instrument group spelling out the responsibilities of each group for installing, maintaining and servicing the instrument. The result of this process will be a joint Supplemental Report to the SAC.

2.3. SAC Review

The SAC will review the Proposal with the Supplement Report and forward the Proposal to the Council with its recommendations.

2.4. Council Approval

The Council will review the Proposal and recommendations from the SAC and vote whether to approve the development of an instrument as a Facility Instrument. In making their decision, the Council will take into consideration the overall disposition of existing and previously approved instruments within the observatory in terms of numbers of supported instruments and their capabilities.

3. Instrument Development Phase

3.1. Liaison

The Director will appoint an individual to be the liaison between the Observatory and the instrument group during the instrument development and commissioning phases. The liaison is expected to maintain regular contact with the instrument group and become familiar with the instrument. The liaison will facilitate the transfer of information between the instrument group and operations staff and will assist the instrument group on all issues having to do with interfaces to the telescope, handling operations, instrument storage, cabling, space for computers, shipping, and services available at the observatory.

3.2. Monitoring

The group developing a Facility Instrument will report periodically to the SAC. During the development phase issues may arise that require revisions to the proposed instrument. These revisions should be discussed in the SAC. If the SAC feels the changes substantially affect the performance, support requirements, or schedule, the matter should be referred to the Council after conferring with the instrument group

3.3. Final Support Agreement

The instrument group will prepare a Final Support Agreement including a spare parts list for Observatory Staff review. Appendix A contains an outline.

The Observatory Staff will review the agreement and report to the SAC stating whether or not the staff agrees with the terms.

3.4. Pre-ship Review:

The Director will conduct a final review of the instrument prior to shipment. In addition to members of the instrument group the reviewers may include representatives of the SAC, the liaison person and observatory staff members associated with operations. The instrument group is expected to address concerns expressed in the review to the satisfaction of the Director before shipping the instrument.

3.5. Commissioning

The instrument group and Observatory staff will mutually develop a commissioning plan for the instrument. The liaison is expected to play a key role in this process. The commissioning plan will be finalized well enough in advance to allow engineering time to be scheduled under the normal TAC process.

At the end of the commissioning period the instrument group will prepare a report to the SAC summarizing the measured instrument performance, noting the areas where the instrument meets its design goals and areas where it falls short. The SAC will review the commissioning report and recommend corrective actions to the instrument group in areas where there are shortcomings.

4. Facility Instrument Acceptance

4.1. Conditions for Acceptance

- a. The SAC has reviewed the instrument performance based on the commissioning report.
- b. Documentation has been delivered including a User's Manual, technical manual(s), all drawings, schematics, and source code necessary for maintaining and supporting the Facility Instrument.
- c. Spare parts are delivered.
- d. Sufficient training and access to the instrument has been provided to the Observatory staff.
- e. A support agreement is in place.

4.2. Reporting

The observatory staff will notify the SAC when items b-d in Section 4.1 are complete. The SAC will report to the Council when the Conditions for Acceptance have been met. In case of a disagreement regarding the Conditions for Acceptance, the SAC will prepare a summary of the instrument status for the Council.

4.3. Final Acceptance

Upon receiving the report from the SAC, the Council either will accept or reject the instrument as a Facility Instrument, or will recommend action to correct deficiencies prior to acceptance.

5. Instrument Upgrades

5.1. Upgrade Proposal

Any member institution may propose upgrades to an in-service Facility Instrument. Upgrades should be discussed ahead of time with the instrument group and must be approved by the institution that owns the instrument. The proposal should describe the proposed changes, who will perform the work, how it is to be funded, and provide a schedule including an estimate of instrument downtime. Any required modifications to the Magellan facility and/or requirements for additional operations support should also be discussed.

5.2. SAC Review

The SAC will review Facility Instrument upgrade proposals and may appoint a committee to consider the Proposal if additional study is required.

If a significant allocation of resources or change in instrument capabilities is involved or if there is not unanimous SAC agreement, the SAC will forward the proposal to the Council with its recommendation.

If the changes are deemed minor, the SAC may approve the upgrade without referral to the Council.

5.3. Approval

The Council will review the SAC's recommendation for upgrade and vote whether to approve the upgrade. The instrument group's home institution has veto power over proposed modifications.

Certain improvements may, in effect, be approved in advance. These might include, for example, purchase of additional filters or gratings.

Upgrades that take place in the course of routine maintenance do not need the approval of the SAC or Council. Such upgrades may not result in a loss of instrument capabilities or impair the ability of the instrument group to service the Facility Instrument. Whenever possible, the observatory staff will consult with the instrument group before making changes. An example would be the replacement of a disk drive with a larger unit. The upgrade will be reported to the instrument group at the earliest possible time. Instrument upgrades will be included as part of regular reports to the SAC on instrument status.

6. Instrument Monitoring, Downgrades & Retirement

6.1. Monitoring instruments in Service

Once a year the operations staff will report to the SAC on the status of all Facility Instruments. The report will describe the overall condition of the Facility Instruments, their current performance, the current level of support required, its impact on operations, and usage statistics. The SAC will in turn report Facility Instrument status to the Council.

Serious problems with Facility Instruments will be brought to the attention of the SAC at the earliest scheduled SAC meeting. These may involve instrument performance, the ability of the observatory to support the instrument, or scheduling conflicts. The SAC will recommend a corrective course of action to the contributing institution, observatory staff and/or the Council as is appropriate.

6.2. Downgrades

Proposals to downgrade a Facility Instrument to User Instrument status or permanently retire an instrument may be submitted to the SAC by any member institution. The SAC will review the Proposal and prepare a recommendation to the Council. The council has final approval over Facility Instrument downgrades or the retirement of instruments.

A retired instrument reverts to the institution that supplied it.

Appendix A: Support Agreement Outline

A.1 Instrument Description

Example:

- Permanently mounted f/11 imager on the folded port instrument with its own rotator and guider. Single dedicated cryo-tiger refrigerator mounted below the azimuth disk. One electronics box mounted on the telescope center section and a SPARC workstation located in the equipment area. Instrument will be continually powered on. Observer's LINUX workstation in the control room shared with other instruments. Excess heat removed using the observatory instrument cooling system.

A.2 Configuration

The following information will be provided relating to the telescope/instrument configuration:

- Specify the intended port.
- Specify the secondary mirror and ADC.
- Provisions for guiding: Does the instrument require one of the observatory guiders and, if so, specify which model?
- Specify instrument size and weight.
- List size and location of instrument racks, compressors, and other equipment.
- Description and location of the control console. Is this dedicated equipment or shared with other instruments?
- Discuss telescope and rotator balance considerations.
- Specify special baffle requirements.
- Cable description and layout. State if the cables are permanently installed and if they are shared with other instruments. Is a cable wrap required?

A.3 Service requirements

The following information will be provided related to controls, utilities, and cabling:

- Requirements for power, compressed air, and coolant.
- Air ducting for heat extraction.
- Requirements for cryogenics.

A.4 Routine Support

The following information regarding routine operation of the instrument will be provided:

- Description of the routine servicing and periodic maintenance that will be performed by the Observatory Staff both when the instrument is on and off the telescope.
- Technical personnel required for operation and an estimated amount of time they will regularly devote to the instrument.
- Consumable supplies required for operations with estimated quantities.
- Power, air, and coolant requirements.
- Description of the procedures required for routine instrument changes. These include pump down and cool down procedures, cabling, power up, filter and mask preparation, preparation of the data system, and actual start-up procedures. Actual handling procedures are described in a later section.
- Requirements for status reports from the support staff to the instrument group. Here the instrument groups would specify what feed back they expect from LCO on the operation and performance of the instrument.
- Instrument mailing list and the names of its members.

A.5 Troubleshooting and repair

The following information will be provided relating to troubleshooting and repair:

- List the subsystems that are serviceable by the observatory staff and describe those repair procedures that may be attempted by the local staff for each subsystem.
- List the critical subsystems and repair procedures that specifically may not be attempted by the local staff.
- Specify procedures that must be followed when a problem occurs. This should include who is the responsible that should be contacted at the home institution, how notification is made, who coordinates the local effort at the observatory.
- Specify who authorizes and pays for replacement parts and contracted services.
- Specify what constitutes chronic or severe problems that go beyond the ability of the staff to maintain the instrument and/or that place excessive demands on the technical staff such that normal observatory operation is impaired. Under these conditions intervention by the instrument group is expected.

A.6 Support provided by the Instrument Group

List the individuals at the home institution that are responsible for supporting the instrument:

- Principal point of contact
- Others: mechanical engineer, software systems, instrument scientist.

Describe the remote help that will be provided:

- Online trouble shooting and consultation.

- Updating documentation.
- Purchasing parts and arranging repair service in the US.
- Specify the period for this support. Normally this would be for the life of the instrument as a Facility Instrument.

Describe the on-site help that will be provided:

- Individuals committed to traveling to Chile when necessary.
- Time to respond.
- Criteria and procedures for authorizing and scheduling trips.

Describe the training that will be provided:

- During the development phase at the home institution.
- On-site at commissioning.
- Over the course of operations.

A.7 Handling & storage fixtures

The following information will be provided relating to handling, storage, and shipping:

- Description of required handling & storage fixtures and a statement of how they are to be provided.
- Procedures for moving the instrument too and from the telescope and mounting it on the telescope.
- Description of the off-telescope storage requirements including amount of space, type of environment, and power or cooling.
- Description of shipping requirements, shipping costs and how arrangements are made. State if this is an on-going expense, e.g. instruments shared with other observatories. If parts of the instrument must be returned to the home institution for periodic upgrade or service, so state.

A.8 Special provisions

- Describe any special provisions, conditions or modifications at the Magellan facility not already covered above and necessary in order to operate the instrument.
- List any factors associated with the instrument that would interfere with the operation of instruments on other ports or that otherwise constrain normal operations.
- Are there arrangements with other organizations, observatories, or groups that affect the way this instrument will be used and supported at LCO?